



CO L O R A D O

**Department of Public
Health & Environment**

Air Pollution Control Division

Technical Services Program

APPENDIX GM2

Standard Operating Procedure for Gas Analyzer Calibrations

Page intentionally left blank

TALBE OF CONTENTS

1	Scope and Applicability	7
1.1	Introduction	7
2	Summary of Method.....	7
2.1	Calibration Equipment.....	7
2.1.1	Calibration System.....	7
2.1.2	Accessories and Incidental Supplies.....	8
2.1.3	Reagents and Standards	9
3	Calibration	9
3.1	Introduction and Summary	9
3.2	Site Inspection	10
4	CO Calibration Procedure.....	11
4.1	Calibration Train Setup.....	11
4.2	Pre-calibration Zero, Span, and Precision Routine	12
4.3	Pre-Calibration Audit, Calibration Adjustment, and Post-Calibration Assessment.....	14
4.3.1	Pre-Calibration Assessment Procedure.....	14
4.3.2	Calibration Adjustment Procedure.....	16
4.3.3	Post-Calibration Assessment Procedure	17
5	SO2 Calibration Procedure	19
5.1	Calibration Train Setup.....	19
5.2	Pre-calibration Zero, Span, and Precision Routine	20
5.3	Pre-Calibration Audit, Calibration Adjustment and Post-Calibration Assessment.....	20
5.3.1	Pre-Calibration Audit Procedure	20
5.3.2	Calibration Adjustment.....	22
5.3.3	Post-Calibration Assessment	23
6	O3 Calibration Procedure	24
6.1	Calibration Train Setup.....	24
6.2	Station Pre-calibration Zero, Span, and Precision Routine	25
6.3	Pre-Calibration Audit, Calibration Adjustment, and Post-Calibration Assessment.....	26
6.3.1	Pre-Calibration Audit Procedure.....	26
6.3.2	Calibration Adjustment.....	27
6.3.3	Post-Calibration Assessment	28
7	CAPS NO2 Calibration Procedure	30
7.1	Calibration Train Setup.....	30
7.2	Pre-calibration Zero, Span, and Precision Routine	31
7.3	Pre-Calibration Audit, Calibration Adjustment and Post-Calibration Assessment.....	32
7.3.1	Pre-Calibration Audit Procedure.....	32
7.3.2	Calibration Adjustment.....	33
7.3.3	Post-Calibration Assessment	35
8	NO_x Calibration Procedure	37
8.1	Calibration Train Setup.....	37
8.2	Pre-calibration Zero, Span, and Precision Routine	38
8.3	Pre-Calibration Audit, Calibration Adjustment and Post-Calibration Assessment.....	39
8.3.1	Pre-Calibration Audit Procedure.....	39
8.3.2	Calibration Adjustment.....	40
8.3.2.1	Molybdenum Converter Models.....	41
8.3.2.2	Photolytic Converter Models	42
8.3.3	Post-Calibration Assessment	43
9	NO_y Calibration Procedure.....	45
9.1	Calibration Train Setup.....	45

9.2	Pre-calibration Zero, Span, and Precision Routine	46
9.3	Pre-Calibration Audit, Calibration Adjustment and Post-Calibration Assessment.....	47
9.3.1	Pre-Calibration Audit Procedure.....	47
9.3.2	Calibration Adjustment.....	48
9.3.3	Post-Calibration Assessment	49
10	Reporting and Filing of Calibration Results.....	51
11	Quality Assurance and Quality Control.....	52
11.1.1	Calibrations.....	52
11.1.2	Documentation.....	52
12	Bibliography.....	52

TABLE OF TABLES

Table 1.	Calibration Ranges for Carbon Monoxide Analyzers.....	16
Table 2.	Calibration Ranges for Sulfur Dioxide Analyzers.....	22
Table 3.	Calibration Range Ozone Analyzers.....	27
Table 4.	Calibration Ranges for Oxides of Nitrogen Analyzers	34
Table 5.	Calibration Ranges for Oxides of Nitrogen Analyzers.....	40
Table 6.	Calibration Ranges for Oxides of Nitrogen Analyzers.....	48

TABLE OF FIGURES

Figure 1.	CO Calibration Setup	54
Figure 2.	SO ₂ Calibration Setup	55
Figure 3.	O ₃ Calibration Setup.....	56
Figure 4.	NO / NO ₂ / NO _x Calibration Setup	57
Figure 5.	NO _y Calibration Setup	58
Figure 6.	Typical zero-air supply system - TAP 701H.....	59
Figure 7.	Calibration \ Audit Worksheet	60
Figure 8.	Ozone Calibration/Audit Worksheet API 400/400A/400E	62
Figure 9.	Flow Measurement.....	64
Figure 10.	Calibration Report.....	65
Figure 11.	NO _x Specific Calibration Report	66

TABLE OF EQUATIONS

Equation 1.	Percent Relative Error	13
Equation 2.	STP Correction Factor.....	14
Equation 3.	True CO Concentration	15
Equation 4.	Percent Relative Error	16
Equation 5.	Relative Error at Full Scale	18
Equation 6.	Zero Corrected Test.....	20
Equation 7.	Percent Relative Error	20
Equation 8.	Percent Relative Error	21
Equation 9.	Relative Error at Full Scale	24
Equation 10.	Percent Relative Error	25
Equation 11.	Percent Relative Error	27
Equation 12.	Relative Error at Full Scale	29
Equation 13.	Percent Relative Error	32
Equation 14.	Percent Relative Error	33
Equation 15.	Relative Error at Full Scale	36
Equation 16.	Percent Relative Error	38
Equation 17.	Percent Relative Error	40

Equation 18. Relative Error at Full Scale	43
Equation 19. Zero Corrected Test.....	46
Equation 20. Percent Relative Error	46
Equation 21. Percent Relative Error	48
Equation 22. Relative Error at Full Scale	50

Page left intentionally blank.

Standard Operating Procedure for Gas Analyzer Calibrations

1 SCOPE AND APPLICABILITY

1.1 Introduction

This standard operating procedure (SOP) document describes the procedures used by members of the Air Pollution Control Division (APCD) Technical Services Program (TSP) to calibrate gas analyzers at the State of Colorado, Department of Public Health and Environment's (CDPHE) air quality monitoring sites. This includes both standard and trace level analyzers at State and Local Air Monitoring Stations (SLAMS), special purpose monitoring (SPM) and NCore monitoring stations. The procedures given in this SOP are a supplement to APCD's Quality Assurance Project Plan (QAPP), the latest information published in the Code of Federal Regulations, and the Operator's manuals.

2 SUMMARY OF METHOD

Calibration of an analyzer or instrument establishes the quantitative relationship between the actual value of a standard, be it a pollutant concentration, a temperature, or a mass value, and the analyzer's response (chart recorder reading, output volts, digital output, etc.). This relationship is used to convert subsequent analyzer response values to corresponding concentrations. Once an instrument's calibration relationship is established, it is checked at reasonable frequencies to verify that it remains in calibration. It is the goal of APCD to perform calibrations on all analyzers quarterly, however, circumstances may require calibrations be performed at the longer frequency of every 6-months. A 6-month calibration frequency still meets EPA recommended calibration frequency criteria.

2.1 Calibration Equipment

2.1.1 Calibration System

The following equipment is required for calibration of CO, SO₂, CAPS NO₂, NO_x, and NO_y gas analyzer:

See Figure 1-6.

- Dilution gas calibrator and zero air generator.
 - The calibrator must have mass flow controllers for dilution air with flow from 0.0 – 10.0 liters per minute (Lpm) and cal gas at 0.0 – 100 ml/min, with these flows as the minimum full scale ranges (Mesa Laboratories, MK01-26 Rev H).
 - The calibrator must have a mixing chamber for dilution air and calibration gas flows.
 - Replaceable outlet particulate filter.
 - High volume/pressure air pump.
 - Permeation dryer, Indicating Silica gel or Calcium Carbonate.
 - Catalytic oxidizer for the removal of hydrocarbons and carbon monoxide.

The following equipment is required for calibration of an ozone analyzer:

- Ozone Transfer Standard: An ozone transfer standard is a transportable device or apparatus which, together with associated operating procedures, is capable of accurately measuring and producing (if an ozone generator is installed) ozone concentrations which are quantitatively related to a

higher level and more authoritative standard. The transfer standard's purpose is to transfer the authority of a Level 1 ozone standard to a remote point where it is used to verify or calibrate an air monitoring analyzer (US EPA, 2013).

- Ozone Generator: A generator providing stable ozone concentrations that can be varied manually or by automatic electronic feedback circuitry. If the transfer standard is or has an ozone generator, no other ozone generator is needed.
- Zero Air Generator: Zero air is required for the calibration of ozone instruments. This air must be ozone-free to 0.001 ppm, and also free of nitric oxide (NO), nitrogen dioxide (NO₂), particulates, and hydrocarbons. Although there are many commercially available zero-air systems, zero air can also be generated by using a series of canisters that contain thermally cracked carbon, Purafil®, and desiccant. Because NO may be difficult to remove, frequent changing of the carbon or use of an NO-to-NO₂ converter may be necessary. When such a converter is used, test the output with a NO/NO_x analyzer to ensure that the residence time in the system is long enough for complete conversion of NO to NO₂.
- The desiccant used with the zero-air system should be changed regularly. A canister system set up with a pump and surge tank can provide a cost-effective zero-air system. If a zero-air system is created, the moisture content must remain constant. Changing humidity can affect the response of UV photometers. Very dry zero air may also be a problem. The scrubber needs time to adjust if the zero air is much drier than the ambient air.
- Output Manifold/Sample Lines: Although the output manifold can be constructed of borosilicate glass or Teflon, Teflon is recommended. The manifold must have an opening that vents excess air to the atmosphere such that the pressure in the manifold is as close to atmospheric pressure as possible. If ozonated air is delivered under too high a pressure, the ozone readings obtained will not be representative. Manifolds collect particulate matter on the internal walls because neither zero air nor sample air is totally particulate-free. Because Teflon manifolds are opaque, it can be difficult to determine whether they are collecting particulates.

2.1.2 Accessories and Incidental Supplies

- External flow transfer standards capable of measuring flows of 10 - 10000 cc/min (Teledyne-API, 2009).
 - All flow transfer standards (such as a BIOS Definer) are to be certified against the APCD's Laboratory Flow Standard, which is certified at a regular interval by the manufacturer against references traceable to an NIST standard (Mesa Laboratories, MK01-26 Rev H).
- Digital thermometer measuring to tenths of a degree Celsius. This field transfer standard should be verified quarterly against an in-house mercury thermometer that is traceable by the manufacturer to a NIST standard.
- Hand held barometer measuring to tenths of an inch Hg. This field transfer standard should be verified quarterly against the in-house digital barometer standard that is traceable by the manufacturer to a NIST standard, and adjusted as needed
- Digital voltmeter (DVM) with a 0 - 1 volt range. It is annually verified against the in-house voltage standard, which has NIST traceability.
- Connecting lines made of 1/4" OD Teflon.

- Teflon™ is an inert material that should be used exclusively throughout the calibration system. It is recommended that Polytetrafluoroethylene (PTFE), Fluoroethylpropylene (FEP) Teflon™ or Perfluoroalkoxy (PFA) tubing be used.
- Calibration sheet (Figure 7).
- The pertinent gas analyzer technical manual. Each station must have a permanent copy of each gas analyzer present.

2.1.3 Reagents and Standards

Certified CO calibration gas cylinder bottle are traceable to a NIST standard via EPA Protocol 2. Pre-dilution concentrations used are usually approximately 300 or 1000 ppm in a balance of CO₂ and air.

Certified SO₂ calibration gas cylinder bottle are traceable to a NIST standard via EPA Protocol 2. Pre-dilution concentrations used are usually approximately 10 to 50 ppm in a balance of nitrogen.

Ozone analyzers used by the CDPHE do not require any reagents. All transfer standard calibration and quality control concentrations are obtained by calibration against sources whose operation must be traceable to NIST Standard Reference Material (SRM) gases via EPA Protocol procedures.

Certified NO calibration gas cylinder bottles are traceable to a NIST standard via EPA Protocol 2. Pre-dilution concentrations used are usually between 10 to 50 ppm in a balance of nitrogen and air.

3 CALIBRATION

This section applies to any calibration and should be understood before proceeding.

3.1 Introduction and Summary

The calibration of a gaseous analyzer centers on introducing known concentrations of a pollutant to the analyzer and adjusting the analyzer so that its readings accurately represent those concentrations (US EPA, 1990). An overview of the calibration process is given below.

1. Site Inspection Summary (Section 3.2):
 - a. General inspection of the station shelter.
 - b. General inspection of all measurement and recording instruments, along with the analyzer, to see if they are working properly.
 - c. Minor maintenance on the shelter or instruments if required and within the scope of the calibration specialist's resources. If any of the analyzer operational parameters are out of specification or nearing being out of specification from the station log sheet target values (See GM1 of this QAPP), the calibration should be halted so repairs and/or major maintenance can be performed prior to calibration.
2. Calibration Procedure Summary (Section 3.3):
 - a. A pre-calibration station span, precision and zero routine is run.
 - b. A pre-calibration audit point at the precision level using the calibration equipment is introduced, plus a calibration zero, to the analyzer.

- c. Performance of any minor maintenance if required and within the scope of the calibration specialist's resources. If major repairs are needed, the calibration should be halted so repairs and/or major maintenance can be performed prior to calibration.
 - d. Adjustment of the analyzer's responses so that they accurately reflect introduced known concentrations of test gas.
 - e. Introduction of five test gas concentrations plus zero air in order to characterize the calibrated analyzer's response curve.
 - f. Determination of the automated zero, span, and precision values.
3. Calculation, recording, and reporting of results.

3.2 Site Inspection

A site inspection is conducted every time a calibration specialist goes to a monitoring station to calibrate, audit, or perform any other kind of calibration unit operation.

The inspection routine includes the following actions:

1. Check that any water drop (if present), and sample lines are not dirty or show condensation.
2. Check that all monitors' operational parameters such as pressure, temperature, and sample flow look normal compared to the values recorded on their calibration stickers and station log sheets. Refer to an analyzer's manual and analyzer log sheet for allowable ranges for each of its diagnostic parameters. If any parameter on any analyzer is out of bounds then the monitoring technician should be notified that day. Maintenance should be performed by the calibration specialist if possible, and a calibration on the analyzer may be necessary.
3. Check that the station temperature high/low readings are within a range of 20 - 30 °C (68 - 86°F).
4. Check the station logs for non-routine actions.
5. Check that all gaseous analyzers and meteorological (met) sensors appear to be reading ambient values that are reasonable given outside conditions and past readings for that individual station. This is done by looking at the real time data logger readings. For the gaseous analyzers, make sure their front panel readings match those on the data logger. For specifics on using the data logger refer to the D1, data logger & Central SOP appendix in this QAPP document.
6. If you need to access the data logger functions through one or more login codes (codes are required) and aren't sure if you're authorized for access, call either the supervisor or the monitoring technician to see if you are. If you know that you are authorized, but have forgotten the login codes, call key contact personnel within the Technical Services Program (TSP) for the codes. Key contact people within the GMM work groups are posted within every monitoring station.
7. Check visually that the meteorological tower's instrument crossbar is properly aligned. Check that the meteorological sensors aren't damaged and are moving without binding.
8. Check that the station structure is not damaged.
9. Check that all analyzer clocks agree with the data logger and that they are showing the proper time (See Appendix GM1 of this QAPP). If any change is made to a device then log the action, date and

calibration specialist's initials in the relevant log. For changes to the data logger clock consult first with GMM supervisory or data management staff.

10. Check that all pumps are running smoothly and are not overly hot to the touch. Check also that exhaust lines between the pump and the analyzer are not rubbing on the pump, which can lead to a hole being worn in the line.
11. Perform a leak check on the analyzer that is to be calibrated.

If anything is found out of the ordinary it is recorded on the relevant log sheet, along with the date and the calibration specialist's initials. The site operator (or work lead or supervisor of the GMM unit if that person is not available) is notified that day. Maintenance should be performed if appropriate and within the scope of the calibration specialist's resources.

4 CO CALIBRATION PROCEDURE

4.1 Calibration Train Setup

The zero air source and the compressed gas cylinder are attached to the dilution calibrator, which is used to mix various levels of test gas. These concentrations are then measured by the analyzer under calibration (Figure 1).

1. Nominally the zero air path (Figure 6) goes through the TAPI 701H zero air supply and on to the dilution calibrator. If the zero air supply does not have its own CO scrubber, attach a separate catalytic oxidizer in the train between the zero air pack and the calibrator. If a commercial system is not used, zero air for the calibration train may be provided as follows:
 - a. First, a high volume/pressure air pump, particulate filter and pressure regulator with a line going to:
 - b. The dryer, a clear plastic cylinder filled with indicating desiccant such as silica gel, with an input and output at either end. The cylinder must be placed on end so that no channeling occurs. Either end may be the input or output. From there a line leads to:
 - c. Scrubber canisters which may contain charcoal and/or Purafil which are not critical for CO but will remove non-hydrocarbon pollutants and reduce reactants from entering the next stage which is:
 - d. The catalytic oxidizer (catox). This is where CO and other hydrocarbons are oxidized. Caution: catox units use very high temperatures. Care must be used in operating these properly so that no injury to the calibration specialist or catalytic oxidizer occurs. See the appropriate manual for the catox. (NOTE: Make sure that it does not exceed its recommended temperature and is allowed to properly cool at the end of the calibration in order to prevent damage to its catalysts.) From there a line leads to:
 - e. The zero air input of the dilution calibrator. The basic model TAPI model 701 includes an oil diaphragm free pump plus scrubbers to remove SO₂, NO, NO₂, O₃, and H₂S. Optional high performance scrubbers are available to remove CO and Hydrocarbons. Make sure the high performance ZAG is only used for CO calibrations. For maintenance requirements of the ZAG please see section 9 of Appendix QA4 of this QAPP. The APCD currently is using TAPI 700 series gas dilution systems which use certified mass flow controllers (MFC) under computer control to provide known concentrations of a pollutant by ratio mixing of zero air and source gas.
2. Connect the bottled CO calibration gas regulator supply line directly to the designated cal gas input of the dilution calibrator. Adjust delivery pressure to about 20 to 30 PSI.

3. Connect a short Teflon line to the output port of the dilution calibrator that will be connected to the supply tee.
4. At the free end of this line connect a tee at one of the tee arms. This is the supply tee.
5. On the other arm of the tee connect an open-ended line. This line should be at least thirty centimeters long, but not longer than 75 centimeters. This is the excess flow line.
6. The calibration train is assembled and all elements are turned on. While the cal train is warming up and stabilizing, the station calibration zero, span and precision routine can be performed. In the case of using a Sabio 2050 external catalytic oxidizer, it takes about 10 minutes for it to stabilize at the required 100° C (for temperature set points, particularly when calibrating hydrocarbons, check with the manual or manufacturer).

WARNING: There must be airflow through the catox when it is turned on or the catalyst elements will be damaged. When the catox is no longer needed, turn off the heater, but keep zero air at full flow going through it until catox temperature reaches <30°C.

4.2 Pre-calibration Zero, Span, and Precision Routine

This routine is done before there is adjustment to the analyzer to help correlate the preceding automatic zeros and spans (z/s) and precisions (p) with the pre-calibration audit responses. It is also done at the end of the calibration procedure to generate new official z/s/p values for the following sampling period until the next calibration. In practice these routines are started just before and after any calibration / audit to allow time to set up or tear down the calibration equipment while they run their course.

If the analyzer is communicating with the data logger over an analog connection, connect a digital volt meter (DVM) or digital chart recorder to the analog output of the monitor or the analog input of the data logger according to ease of accessibility. This step should not be performed if the analyzer is communicating with the data logger over a digital connection (GSI or Modbus). Readings on the data logger are taken from the CO channel (and not, for example, from the CO_RAW channel). The CO channel is a calculation of CO_RAW-K1 where K1 is the result of the last successful zero phase, thereby zero adjusting the real-time data.

1. Take the CO analyzer offline.
2. Put the analyzer into zero mode. Along with manual spans and precisions this can be done through the front panel of the analyzer or through the data logger. Refer to analyzer and data logger manuals for specifics on how to do this.
3. To emulate the midnight zero process the analyzer is allowed to stabilize for five minutes. Then during the second five minutes the calibration specialist takes readings as the data logger does during the automatic zero. However, instead of taking the average of many readings over the second five minutes, it is usual just to take one reading from each of the displays if the readings are constant, varying less than ± 0.1 ppm over five minutes. This taking of one reading per display is done for all of the points introduced during the calibration procedure. If the readings for all points taken in the calibration vary $>\pm 0.1$ ppm within a five minute time frame, then a taking of ten readings evenly spaced over five minutes is required with the average being recorded. A note in the analyzer log and calibration sheet comments section should flag the instability. Take readings from:
 - a. The data logger concentration value. For analyzers with a CO Raw channel, be sure to use the CO channel instead. This is the most important value as these are the values that ultimately get reported to AQS
 - b. The front panel display.

- c. A Digital Volt Meter (DVM) reading of the analog output line.
- d. The data logger voltage reading.
- e. The site chart recorder reading if present.

Record all readings on the calibration sheet. This is done for all of the points introduced during the calibration procedure. Make sure all voltage readings and concentration readings agree with each other.

4. Take the analyzer out of zero mode.
5. Put the analyzer into span mode.
6. Let stabilize for five minutes. Within the second five minutes take the readings and record.
7. Zero-correct the data logger span results.

$$\text{span value} - \text{zero value} = \text{zero corrected span (zcs)}$$

8. Calculate the percentage relative error (%RE) of the span and record on the calibration sheet.

Equation 1. Percent Relative Error

$$\frac{\text{zcs} - \text{span bottle value}^*}{\text{span bottle value}^*} * 100\% = \%RE$$

*Use the EPA Protocol 2 measured sticker value on the station test gas bottles if the test gas is used directly and not diluted by an in-station dilution calibrator. Note: it is usual for a positive 2 – 3 %RE at the span level if the analyzer is properly calibrated at the zero and precision levels. If a dilution calibrator is used to span the analyzer, use the dilution calibrator output concentration reading in place of the span bottle value.

9. Take the analyzer out of span mode.
10. Put the analyzer into precision mode.
11. Take the readings (just as in span mode). Calculate the %RE of the zero corrected precision (Equation 1), and record. Use the EPA Protocol 2 measured sticker value on the bottle. If a dilution calibrator is used for precisions, use its test gas output reading on the display in place of the precision bottle value.
12. Return analyzer to sample mode.

These points may also be run using the built-in routines in the data logger which will store the results in the site's calibration report. If the full built-in auto span, precisions and zeros are run to their end, K1, a math constant used for zero adjusting CO from CO Raw, will be updated. This is allowable and makes no great impact on the calibration procedure, but the calibration specialist must be aware of this at the time. The K1 constant in any case will be set to 0 later by the calibration specialist during this calibration. Just follow the same data collection process for the various displays/devices.

4.3 Pre-Calibration Audit, Calibration Adjustment, and Post-Calibration Assessment

4.3.1 Pre-Calibration Assessment Procedure

Introduction

From the transfer standard calibrator set up introduce zero and precision levels test gas to the analyzer. Calculate %RE for the zero corrected precision level results. If this exceeds +/- 10 %RE, follow with a full five point plus zero calibration assessment audit (the same as a post-calibration assessment in method below) before any adjustment is made to the analyzer. This assessment audit is the same as described below in section 9.3.3.3 Post-Calibration Assessment. This is to characterize the out-of-spec condition fully, and the information will be used during data validation.

If the analyzer fails the pre-calibration assessment audit then repairs and calibration of the instrument are done as soon as possible after the audit. If the repairs required are beyond the resources of the calibration specialist then the monitoring technician for that station is notified immediately. Proceed to the calibration adjustment procedure in Section 9.3.3.2 if the pre-calibration audit results less than +/- 10 %RE. Failed pre-calibration assessment audits require an electronic message in the data logger that will to be use for data validation purposes. The procedure for performing the pre-calibration audit is given below.

Procedure

1. If a TAPI 700x type calibrator with certified MFCs is used then simply request the desired CO concentration level or ZERO point needed. Refer to the calibrator’s operating manual for procedures on how to generate manual concentrations from the calibrator (Teledyne-API, 2009). For a “dumb” calibrator with certified MFCs use the calibration curve for the specific MFC to set the flow rate required using the formula in step 8 below to calculate the desired flows and concentration.
2. Let the dilution airflow in the calibrator stabilize. If taking flow measurements and the flow meter used does not automatically apply temperature and pressure compensation then these will need to be calculated separately per the next step #4. Let the thermometer and barometer equilibrate. This should usually take less than five minutes.
3. Measure the dilution airflow with the flow meter:
 - a. Make sure that the CO cal gas is not mixing with the dilution air. Connect the input of the external flow meter to the exit port of the calibrator before the supply tee.
 - b. Take at least two temperature readings bracketing in time the flow measurement period and one barometer reading. Measure ten readings of the dilution airflow through the external flow meter. Average the ten readings and record on the calibration sheet. This is the raw dilution airflow rate.
 - c. If the flow meter does not do STP correction or it is in “Volumetric” mode which does not apply correction then use this formula for a dimensionless correction factor,

Equation 2. STP Correction Factor

$$\frac{BP * 298.2}{29.92 * (273.2 + T)} = c$$

where

BP = barometric pressure to nearest hundredth of an inch of Hg.

T = air temperature in degrees C to nearest tenth of a degree.

cf = unitless correction factor to STP.

298.2 = Kelvin degrees equivalent for a 25 degree C temperature standard (273.2 + 25). A temp standard of 0 degree C = 273.2

29.92 = inches of Hg at one atmosphere.

- d. Calculate c.f. and multiply the raw flow rate by this to get the dilution flow rate at STP of 25 degrees C and 29.92" Hg. If the MFC manufacturer uses a different STP baseline then use those parameters in the correction. TAPI for example, uses an STP of 1atmosphere and 0 degrees C so the formula would use 273.2 instead of 298.2
 - e. Record all calculations and results on the calibration sheet.
4. Disconnect the analyzer sample line from the manifold, if present. Make sure to plug up the hole on the manifold if other analyzers are still sampling from it.
 5. If a through-the-probe z/s/p supply is set up for the CO analyzer, disconnect the z/s/p supply line at the end of the last valve solenoid.
 6. If no manifold or through-the-probe z/s/p system is present, disconnect the sample inlet line at the back of the CO analyzer and attach to the supply tee's trunk. Reconnect the calibrator's output port to the tee's arm through the supply line. The excess flow from the end of the excess line should be about 10 to 50% of analyzer flow for all test points. At this time only zero air should be going into the analyzer.
 7. Allow at least five minutes after the analyzer has stabilized. Record the results on the calibration sheet. This is the pre-calibration zero air concentration reading.
 8. Generate a CO flow that will cause a 10 to 20 % full scale of reading (the precision level) when diluted (see step 1 above). Measure and correct the measured flow to STP as done with the zero air. The unmixed CO cal gas has a separate port on the calibrator for measuring its flow, (refer to the appropriate calibrator manual).
 9. If using a manually flow measured calibrator (this step not necessary for an automatic calibrator with certified mass flow controllers) calculate the CO concentration in ppm (true [CO]) from mixing this cal gas flow with the dilution flow.
 - a. Use the formula below and the TAPI 700 output readings for gas and zero air dilution flows to calculate the TAPI 700 is working correctly, and that none of the MFC usage parameters have been exceeded. The MCF's should not be used below 10% of full scale or above 90% of full scale for older (99% for newer) MFCs.

Equation 3. True CO Concentration

$$\frac{CONC * Fg}{(Fd + Fg)} = true[CO]$$

where:

CONC. = concentration of cylinder calibration gas in ppm.

Fg = flow rate of calibration gas in STP cc/min.

Fd = flow rate of dilution zero air in STP cc/min.

- b. Calculate the concentration of the diluted calibration gas (true [CO]) in ppm.

10. Mix the CO cal gas and dilution air and let the analyzer sample it. Allow at least five minutes after a stable response from the analyzer is achieved. Record the results on the calibration sheet. Zero correct the results.

Calculate the relative error of the analyzer’s response

Equation 4. Percent Relative Error

$$\frac{\text{Analyzer Reading}/(\text{DAS}) - \text{true}[\text{CO}]}{\text{true}[\text{CO}]} * 100\% = \%RE$$

11. If the precision level error is < +/- 10% RE a full assessment audit is not required, proceed to 3.3.3.2. If it equals or exceeds +/-10%RE, follow with a full four point plus zero calibration assessment audit (the same as a post-calibration assessment in section 3.3.3.3 below) before any adjustment or repairs are made to the analyzer. This is to characterize the out-of-spec condition fully, and the information will be used during data validation. Additionally, if the assessment fails, documentation of this failure in a Message to Central is required as described in Section 3.3.3.3 Step 11.

4.3.2 Calibration Adjustment Procedure

Introduction

After the pre-calibration audit, the analyzer is adjusted (calibrated) at the zero and precision levels so that the analyzer most closely matches the known concentrations produced by the calibration system at the zero and precision levels. After this is done, a five level plus zero multipoint post-calibration assessment (Section 9.3.3.3) is reintroduced to characterize the analyzer response over the entire measurement range. The calibration points are generated by diluting a higher concentration of CO from a NIST-traceable calibration gas to a target concentration. The recommended ranges for the multi-point calibration points are detailed in Table 1. As each calibration point is generated, the responses shown by the data logger should be compared to the calculated value.

Table 1. Calibration Ranges for Carbon Monoxide Analyzers

CO Calibration Ranges		
	<i>(Trace)Range</i>	<i>(Standard) Range</i>
Units	Parts per million (ppm)	Parts per million (ppm)
Calibration scale	0 to 5.0 ppm	0 to 10.0 ppm
Compressed gas cylinder	60-1000 ppm*	100-2500 ppm*
* Based on calibrator mfc ranges: gas1 = 50ml/min, gas2 = 100 ml/min, dil = 10 or 20 l/min		
Calibration points		
Level 1	4.0 - 5.0 ppm	8.0 - 10.0 ppm
Level 2	2.5 – 3.5 ppm	5.0 - 7.5 ppm
Level 3	1.5 – 2.5 ppm	3.0 - 4.5 ppm
Level 4	0.5 – 1.0 ppm	1.0-2.0 ppm
Level 5 - zero	0 - 0.01 ppm	0 - 0.5 ppm

Level 4 is the accepted precision level that is used to adjust the calibration of the analyzer with as little error as possible (along with Level 5, or the zero level). The procedure for performing the calibration adjustment is given below.

Procedure

1. If the precision level error is $< \pm 10\%$ full scale RE and a full 5 point assessment is not required, leak check the analyzer.
2. Send zero air to the analyzer again. Let the analyzer stabilize. Go to the Calibration Menu. Select CO BACKGROUND and then ENTER.
3. Send 10 to 20% full scale of CO to the analyzer. Let the instrument stabilize for at least five minutes.
4. From the Calibration Menu, choose CO COEFFICIENT. Dial in the true CO concentration being introduced to the analyzer. Press ENTER.
5. Send zero air again to the analyzer. Let it stabilize for at least five minutes. Readjust the zero display value if necessary and repeat steps 1-4 and then come back to this step. Several jumps between the zero air and the 10 to 20 % full scale level, along with calibration adjustments, may be required. After all adjustments are done, let the analyzer stabilize on a cal zero input.

4.3.3 Post-Calibration Assessment Procedure

Introduction

The post-calibration assessment challenges the analyzer with five different test gas concentrations levels plus a zero to evaluate the accuracy of the new calibration. The assessment begins with a zero point followed by points at $< 20\%$ (Level 4 - precision), $> 80\%$ (Level 1 - span), $\sim 60\%$ (Level 2), and $\sim 40\%$ (Level 3). Results for these tests are used to evaluate the relative error at full scale. Concentration levels are generated as described in the pre-calibration assessment (3.3.3.1). The procedure for performing the post-calibration assessment is given below.

Procedure:

1. After the cal zero input is stable, record the results on the calibration sheet.
2. Send the 10 to 20% full scale gas to the analyzer. Let it stabilize for at least five minutes. Record the results on the calibration sheet.
3. Introduce a Level 1 concentration (greater than 80% full scale to the analyzer). Let it stabilize for at least five minutes. Record results on the calibration sheet.
4. Measure and generate three more CO concentrations that come in at approximately 70, 50, and 30% of full range. Introduce to the analyzer as above. Record the results on the calibration sheet.
5. Send a final zero air to the analyzer and record the results. Calculate a least-squares linear regression between the known CO concentrations (including the zero point) as the ordinate and the zero corrected analyzer responses as the abscissa. Record slope, intercept, and correlation coefficient on the calibration sheet. Also calculate, using this response curve, a %REFS for a calibrated analyzer response given a known introduced concentration of exactly 90% of the full measurement range of the analyzer.

- The criteria for a successful calibration is where all non-zero test points after the calibration adjustment show a $\leq \pm 10\%$ full scale error compared to the final best fit regression calibration line. The precision level should be as close to 0% error as possible. Due to the nature of the analyzer, this often results in upper range test points approaching the criteria limit and this is considered normal. If the post-calibration assessment begins to show a failure at any point, and repeating previous analyzer adjustments do not solve the problem, then maintenance is probably needed on the analyzer.

Equation 5. Relative Error at Full Scale

$$\frac{[(90\% \text{ full scale} * m) + i] - 90\% \text{ full scale}}{90\% \text{ full scale}} * 100 = \%REFS$$

where:

m = slope of response curve.

i = intercept of response curve.

90% full scale = 20 ppm (5 ppm at La Casa station).

%REFS = Relative Error at Full Scale

- Reattach the analyzer sample line so that it reads ambient.
- Do another on-site system zero, span and precision routine like the one done before the calibration (Section 3.3.2). Record results on the calibration sheet and on the calibration sticker. These are the new midnight z/s/p values.
- Record analyzer parameters, especially the new analyzer calibration settings, from the front panel display on the calibration sticker and sheet.
- Enable the analyzer on the data logger. Record the MST time the instrument was brought back on line on the calibration sheet and on the station CO log. Put the calibration sticker on a surface near the analyzer so that it is easily read.
- On the data logger message window to Central type and send:

C:CO, Z=aaa, S=bbb (bot xxx), P=ccc (bot yyy), ddd <enter> where:

aaa = data logger CO zero reading in ppm.

bbb = data logger CO uncorrected span reading in ppm.

xxx = span bottle concentration if not diluted.

ccc = data logger CO uncorrected precision reading in ppm.

yyy = precision bottle concentration if not diluted.

ddd = calibration specialist's initials.

This is a message through the data logger to the GMM unit worker responsible for z/s/p records, reporting the new z/s/p results generated after the calibration. In the event of a failed precalibration audit or assessment, a separate message is sent to Central in the form of

“CO CAL FAILED AUDIT”,

(in all CAPS) followed by a general description in regular text and the calibrator's initials. This is to highlight important cal/audit information for the purposes of data validation.

- Record analyzer parameters and calibration and maintenance actions on the station CO log.

5 SO₂ CALIBRATION PROCEDURE

5.1 Calibration Train Setup

1. Connect the clean air supply directly to the zero air input of the calibrator (Figure 1).
2. Before the SO₂ cal gas cylinder is connected to the calibrator, its line and regulator must be purged at least three times. This is done in order to remove all ambient air from the regulator. (Ambient air in the regulator can dilute the SO₂ and bias the calibration results and introduce ambient contaminants that interact with the SO₂.) The following describes the line and regulator purging action:
 - a. Open the regulator and cylinder valves. The closed quick connect will keep the cal gas from escaping
 - b. Close the cylinder valve.
 - c. Push the end of the quick connect nozzle against a clean, flat surface to partially release the pressure within the regulator and line. Carefully watch the two regulator gauges and do not let either of them fall to zero. A positive pressure compared to ambient must be kept so that room air will not surge back into the line and regulator. To stop the release of cal gas, pull the quick connect nozzle away from the flat surface.
 - d. Repeat Steps a through c two times.
 - e. Open the cylinder valve to recharge the regulator and line to full pressure as indicated by the two regulator gauges.
3. After purging, connect the SO₂ cal gas regulator line directly to the cal gas input of the dilution calibrator. Adjust delivery pressure between 20 to 30 psi.
4. Connect a Teflon line to the exit port of the transfer standard calibrator. The length of this line should be of sufficient length to reach from the transfer standard (TS) calibrator to the back of the station (Stat) calibrator or the station analyzer. This is the transfer standard calibrator supply line (supply line). Leave this other end of this line unconnected end for now.
5. The introduction of test gas to the analyzer can be performed in one of two ways depending upon how the station calibrator is configured for the nightly performance tests. The transfer standard calibrator should be configured similarly to the station calibrator if possible. If the station calibrator is configured to introduce test gas through the probe (TTP) then the transfer standard calibrator should be configured likewise. The same is true if the station calibrator is configured to the back of the analyzer (BOA). In most situations the site calibration line can be removed directly from the back of the station calibrator and connected to the transfer standard calibrator output line with a Teflon union. If the a solenoid manifold is used external to the station calibrator to direct test gas TTP to individual analyzers, then it is acceptable to connect the transfer standard output line to the station TTP calibration line on the output side of the solenoid. Simply disconnect the TTP calibration line from the output side of the solenoid and connect it to the transfer standard output with a Teflon union. This method eliminates the need to activate the solenoid for the entire length of the calibration. An exception to the above methods is if the station calibrator is connected directly to a calibration port on the back of the analyzer. In this situation the sample line is removed from the sample inlet port on the back of the analyzer and the transfer standard output line is connected directly to the sample inlet port through the use of a Teflon tee. A 12" (or >) length of clean Teflon is connected to the empty leg of the tee that will be used as a vent to bleed off excess test gas that is introduced to the analyzer by the transfer standard calibrator to prevent back pressure in the analyzer.

5.2 Pre-calibration Zero, Span, and Precision Routine

This routine is done before there is adjustment to the analyzer to help correlate the preceding automatic zeros and spans (z/s) and precisions (p) with the pre-calibration audit responses. It is also done at the end of the calibration procedure to generate new official z/s/p values for the following sampling period until the next calibration. In practice these routines are started just before and after any calibration / audit to allow time to set up or tear down the calibration equipment while they run their course.

If the analyzer is communicating with the data logger over an analog connection, connect a digital volt meter (DVM) or digital chart recorder to the analog output of the monitor or the analog input of the data logger according to ease of accessibility. This step should not be performed if the analyzer is communicating with the data logger over a digital connection (GSI or Modbus). Readings on the data logger are taken from the SO₂ channel (and not, e.g., the SO₂ MAX channel).

1. Take the SO₂ analyzer offline (See Appendix GM1 of this QAPP).
2. Start an automatic precision/zero routine. This is done by a command through the data logger. Allow this routine to run fully until its automatic ending. During the run make sure that all readings from the front panels of the station calibrator and SO₂ analyzer match the numbers seen in the data logger. Record the final reported numbers on the cal sheet. A precision is done before a span because the SO₂ analyzer is more sensitive to conditioning effects at this level, and the purpose of the pre-cal precision is to emulate the midnight precisions as closely as possible.
3. Start an automatic span/zero routine as done in the above Step2 with the precision. If a second auto zero is not needed, the automatic span/zero routine can be aborted through the data logger after the span part of the cycle is finished; but if done so, the last five minute readings of the station calibrator and analyzer during span must be manually averaged as no report will be provided by the data logger.
4. Zero-correct the data logger precision and span test levels (t) results.

Equation 6. Zero Corrected Test

$$t - \text{zero value} = \text{zero corrected test level (zct)}$$

5. Calculate the percentage relative error (%RE) of the two zcts and record on the calibration sheet.

Equation 7. Percent Relative Error

$$\frac{zct - \text{Actual Concentration} *}{\text{Actual Concentration} *} * 100\% = \%RE$$

*Actual Concentration is the concentration of the test gas as reported by the station calibrator system through the data logger

The pre-calibration span and precision plus station zero can also be run manually through the data logger, but the calibration specialist must be careful to emulate automatic phase times so that conditioning effect differences between previous midnight auto spans and precisions and this pre-calibration span and precision can be minimized. For some diagnostic purposes a manual running of the precision and span is sometimes more useful and practical than using the automatic routines. The manually triggering of relays through the data logger is non-routine and the procedure to perform this task is not included in this SOP. Contact the Data Manager to attain information on how to perform this task.

5.3 Pre-Calibration Audit, Calibration Adjustment and Post-Calibration Assessment

5.3.1 Pre-Calibration Audit Procedure

Introduction

From the transfer standard calibrator set up and introduce zero and precision levels test gas to the analyzer. Calculate %RE for the zero corrected precision level results. If this exceeds +/- 10.1 %RE, follow with a full five point plus zero calibration assessment audit (the same as a post-calibration assessment in method below) before any adjustment is made to the analyzer. This assessment audit is the same as described below in section 4.3.3.3 Post-Calibration Assessment. These subsequent assessment levels are used to characterize the out-of-spec condition fully, and the information will be used during data validation. Failed pre-calibration assessment audits require an electronic message in the data logger that will to be use for data validation purposes.

If the analyzer fails the pre-calibration assessment audit then repairs and calibration of the instrument are done as soon as possible after the audit. If the repairs required are beyond the resources of the calibration specialist then the monitoring technician for that station is notified immediately. Proceed to the calibration adjustment procedure in Section 4.3.3.2 if the pre-calibration audit results less than +/- 10.1 %RE. The procedure for performing the pre-calibration assessment is given below.

Procedure

1. Generate a zero point (Level 5) from the TS calibrator. If a TAPI 700x calibrator with certified MFCs is used then simply request the desired SO₂ concentration level or ZERO point. Refer to the calibrator's operating manual for procedures on how to generate manual concentrations from the calibrator (Teledyne-API, 2009). Make sure the correct port and SO₂ tank concentration are programmed into the calibrator.
2. Let the dilution airflow in the calibrator stabilize. This should usually take less than five minutes.
3. Connect the transfer standard calibrator to the analyzer's inlet system. This connection can be made several ways depending upon how the station calibrator is configured with the inlet system. Please see Section 4.3.1 Step 5 for a more detailed description of the setup options.
4. Send zero air through the probe to the analyzer from the TS calibrator. Be sure that excess supply flow at the probe is 10 to 50% greater than analyzer flow (compare total flows of analyzer and TS calibrator).
5. Allow at least five minutes after the analyzer has stabilized. Record the results on the calibration sheet. This is the pre-calibration zero air concentration reading.
6. Generate a test SO₂ flow that will cause a 10 to 20 % full scale of reading (the precision level). The MFCs in the TS calibrator should not be used below 10% or above 90% of their full scale for older TAPI 700xs. Some of the newer MFCs in newer TAPI 700xs are capable of using an upper range of 99% of their full scale, but if in doubt use the more restrictive range when generating a concentration while keeping in mind that an excess of gas must be provided to the probe.
7. Allow at least five minutes after a stable response from the analyzer is achieved. Record the results on the calibration sheet. Zero correct the results. Note: at lower SO₂ concentrations equilibration time may be long; it is important that the analyzers response is allowed to plateau.

Calculate the relative error of the analyzer's response

Equation 8. Percent Relative Error

$$\frac{\text{Analyzer Reading} / (\text{DAS}) - \text{true}[SO_2]}{\text{true}[SO_2]} * 100\% = \%RE$$

8. If the precision level error is $< \pm 10.1\%$ RE a full assessment audit is not required, proceed to 4.3.3.2. If it exceeds $\pm 10.1\%$ RE, the pre-calibration assessment fails, follow with a full four point plus zero calibration assessment audit (the same as a post-calibration assessment in section 4.3.3.3 below) before any adjustment or repairs are made to the analyzer. This is to characterize the out-of-spec condition fully, and the information will be used during data validation. Additionally, if the assessment fails, documentation of this failure in a Message to Central is required as described in Section 4.3.3.3 Step 10.

5.3.2 Calibration Adjustment

Introduction

After the pre-calibration audit, the analyzer is adjusted (calibrated) at the zero and precision levels so that the analyzer most closely matches the known concentrations produced by the calibration system at the zero and precision levels. After this is done, a five level plus zero multipoint post-calibration assessment (Section 4.3.3.3) is reintroduced to characterize the analyzer response over the entire measurement range. The calibration points are generated by diluting a higher concentration of SO₂ from a NIST-traceable calibration gas to a target concentration. The recommended ranges for the multi-point calibration points are detailed in Table 2. As each calibration point is generated, the responses shown by the data logger should be compared to the calculated value.

Table 2. Calibration Ranges for Sulfur Dioxide Analyzers

SO₂ Calibration Ranges	
Units	Parts per billion (ppb)
Full scale range	0 to 200 ppb
Compressed gas cylinder	10-20 ppm*
<small>* Based on calibrator mfc ranges: gas1 = 50ml/min, gas2 = 100 ml/min, dil = 10 or 20 l/min</small>	
Calibration points	
Level 1	150-200 ppb
Level 2	100–150 ppb
Level 3	50–100 ppb
Level 4	10–50 ppb
Level 5 - zero	0-0.1 ppb

Level 4 is the accepted precision level that is used to adjust the calibration of the analyzer with as little error as possible (along with Level 5, or the zero level). The procedure for performing the calibration adjustment is given below.

Procedure

1. To start the analyzer calibration adjustment (if needed), introduce zero air again to the analyzer and let the analyzer stabilize.
2. TAPI 100E/EU and T100/U: Navigate to the calibration menu, calibrate zero. Display concentration will go to 0.000.
3. Generate the precision level SO₂ concentration and direct it to the analyzer. The concentration generated by the TS calibrator is referred to as the “true” concentration. Let the analyzer stabilize.

4. TAPI 100E/EU and T100/U: Navigate to the calibration menu, calibrate span, and input the true precision level concentration.
5. TAPI 100E and TAPI 100A: To auto calibrate analog outputs go to DIAG menu, then ANALOG I/O CONFIGURATION. Press ENTER. On AOUTS CALIBRATED menu, press ENTER. A YES signal will show auto calibration completed. To adjust analog output offsets, from ANALOG I/O CONFIGURATION menu, press ENTER.
6. TAPI 100E and TAPI 100A: Press SET until CONC_OUT_X:1V, CAL (where X=output channel under adjustment) appears. Press EDIT. Press SET until CONC_OUT_X REC OFS:0 mV appears. Press EDIT and then enter channel offset value in mV. Adjust the offset until the data logger reading matches the front panel display of the analyzer.
7. **This and all following steps in section 9 apply equally to all TAPI 100 versions.** Steps 1 thru 6 can be repeated if the calibration settings from the initial calibration or subsequent calibrations are not sufficiently accurate. This is accomplished by independently sending zero air and known test gas concentrations (10 to 20% of calibration full scale) to the analyzer to assess the accuracy of the calibration. If the results are not optimal, repeat steps 1 thru 6. Several jumps between the zero air and the test gas, along with calibration adjustments, may be required. Record the calibration results on the calibration sheet.

5.3.3 Post-Calibration Assessment

Introduction

The post-calibration assessment challenges the analyzer with five different test gas concentrations levels plus a zero to evaluate the accuracy of the new calibration. The assessment begins with a zero point followed by points at <20% (Level 4 - precision), >80% (Level 1 - span), ~60% (Level 2), and ~40% (Level 3). Results for these tests are used to evaluate the relative error at full scale. Concentration levels are generated as described in the pre-calibration assessment (4.3.1). The procedure for performing the post-calibration assessment is given below.

Procedure:

1. Send precision level gas to the analyzer. Let it stabilize for at least five minutes. Record the results on the calibration sheet.
2. Introduce a Level 1 concentration (greater than 80% full scale to the analyzer). Let it stabilize for at least five minutes. Record results on the calibration sheet.
3. Measure and generate three more SO₂ concentrations that come in at approximately 70, 50, and 30% of full range. Introduce to the analyzer as above. Record the results on the calibration sheet.
4. Send a final zero air to the analyzer and record the results. Calculate a least-squares linear regression between the known SO₂ concentrations (including the zero point) as the ordinate and the zero corrected analyzer responses as the abscissa. Record slope, intercept, and correlation coefficient on the calibration sheet. Also calculate, using this response curve, a %REFS (Equation 6) for a calibrated analyzer response given a known introduced concentration of exactly 90% of the full measurement range of the analyzer.
5. The criteria for a successful calibration is where all non-zero test points after the calibration adjustment show a <+/-2% full scale error from the final best fit regression calibration line. The precision level should be as close to 0% error as possible. If the post-calibration assessment begins to show a failure at any point, and repeating previous analyzer adjustments do not solve the problem, then maintenance is probably needed for the analyzer.

Equation 9. Relative Error at Full Scale

$$\frac{[(90\% \text{ full scale} * m) + i] - 90\% \text{ full scale}}{90\% \text{ full scale}} * 100 = \%REFS$$

where:

m = slope of response curve.

i = intercept of response curve.

90% full scale = 180 ppb (calibration scale 0-200ppb).

%REFS = Relative Error at Full Scale

6. Reattach the station calibrator's supply line back to its solenoid valve on the span panel.
7. Do another zero, span and precision routine as performed in Section 4.3.2. Record results on the calibration sheet and on the calibration sticker.
8. Record analyzer parameters, especially the new analyzer calibration settings (slope, offset), from the front panel display on the calibration sticker and sheet.
9. Enable the analyzer. Record the MST time the instrument was brought back on line on the calibration sheet and on the station SO₂ log. Put the calibration sticker on a surface near the analyzer so that it is easily read.
10. Enter the calibration results in a "message to central". On the data logger message window to Central type and send:

C:SO₂, Z=aaa, S=bbb, P=ccc , ddd <enter> where:

aaa = data logger SO₂ zero reading in ppm.

bbb = data logger SO₂ uncorrected span reading in ppm.

ccc = data logger SO₂ uncorrected precision reading in ppm.

ddd = calibration specialist's initials.

This is a message through the data logger to the GMM unit worker responsible for tracking calibrations in the ZSPTracking database. This message is permanently stored in the AirVision system and information from this message is manually inputted into the ZSPTracking database.

In the event of a failed precalibration audit or assessment, a separate message is sent to Central in the form of

SO2 CAL FAILED AUDIT,

(in all CAPS) followed by a general description in regular text and the calibrator's initials. This is to highlight important cal/audit information for the purposes of data validation.

11. Record analyzer parameters and calibration and maintenance actions on the station SO₂ log.

6 O3 CALIBRATION PROCEDURE

6.1 Calibration Train Setup

A level 3 ozone transfer standard is used to calibrate the ozone analyzer. The transfer standard calibrator is equipped with an internal zero air pump, but may also use an external zero air source (TAPI 701(H) zero air pack). The transfer standard calibrator internally generates, and its photometer measures, ozone concentrations that are then

used to challenge the analyzer under calibration. See the Standards SOP Appendix QA2 and the transfer standard calibrator’s operational manual for more information.

1. Connect the zero air supply output to the zero air port on the calibration transfer standard (Figure 1), if the calibrator’s internal zero air pump isn’t being used.
2. Turn on and allow the zero air supply and transfer standard calibrator to warm up, during which the pre-calibration Zero, Span, and Precision routine can be performed (5.3.2).
3. After the station pre-calibration Zero, Span, and Precision routine has been completed, disconnect the test gas supply line from the station calibrator at its external valve output.
4. Connect the open end of the station’s calibrator test gas supply line to the output port of the transfer standard calibrator to introduce calibration ozone concentrations to the analyzer. The station calibrator’s gas supply line leads outside of the shelter and up to the analyzer’s sample line inlet at the probe.

6.2 Station Pre-calibration Zero, Span, and Precision Routine

This routine is done prior to adjusting the analyzer to help correlate the preceding automatic zeros and spans (z/s) and precisions (p) with the pre-calibration audit responses. It is also done at the end of the calibration procedure to generate new official z/s/p values for the following sampling period until the next calibration. In practice these routines are started just before and after any calibration or audit and can be performed while the calibration or auditing staff is performing set up or take down of their equipment.

1. Take the O₃ analyzer channel offline.
2. Start an automatic precision/zero routine. This is done by a command through the data logger. Allow this routine to run fully until its automatic ending. During the run make sure that all readings from the front panels of the station calibrator and ozone analyzer match the numbers seen in the data logger. Record the final reported numbers on the calibration sheet. A precision is done before a span because the ozone analyzer is more sensitive to conditioning effects at this level, and the purpose of the pre-cal precision is to emulate the midnight precisions as closely as possible.
3. Start an automatic span/zero routine as done with Step 2.
4. Zero-correct the data logger precision and span test level (t) results.

$$t - \text{zero value} = \text{zero corrected test level (zct)}$$

5. Calculate the percentage relative error (%RE) of the precision and span zct’s and record on the calibration sheet.

Equation 10. Percent Relative Error

$$\frac{zct - \text{Actual Concentration}^*}{\text{Actual Concentration}^*} * 100\% = \%RE$$

*Actual Concentration is the concentration of the test gas as reported by the station calibrator through the data logger.

The pre-calibration span and precision plus station zero can also be run manually through the data logger. The calibration specialist must be careful to emulate automatic phase times so that conditioning effect differences between previous midnight auto spans and precisions and this pre-calibration span and precision can be minimized. For some diagnostic purposes a manual running of the precision and span is sometimes more useful and practical than using the automatic routines. The manually triggering of relays through the data logger is non-routine and the procedure to perform this task is not included in this SOP. Contact the Data Manager to attain information on how to perform this task.

6.3 Pre-Calibration Audit, Calibration Adjustment, and Post-Calibration Assessment

6.3.1 Pre-Calibration Audit Procedure

Introduction

From the transfer standard calibrator introduce to the analyzer zero and precision levels. Calculate %RE for the zero corrected precision level results. If this equals or exceeds +/- 7%RE, follow with a full five point plus zero calibration assessment before any adjustment is made to the analyzer. This assessment is the same as described below in section 9.3.3.3 Post-Calibration Assessment. This is to characterize the out-of-spec condition over the full measurement range of the analyzer, and the information will be used during data validation.

If the analyzer fails the assessment audit then repairs, when necessary, and calibration of the instrument are done as soon as possible after the check. If the repairs required are beyond the scope of the calibration specialist then the site operator is notified immediately. Failed pre-calibration assessment audits require an electronic message in the data logger that will be use for data validation purposes. The procedure for performing the pre-calibration assessment is given below.

Procedure

1. If not already done, connect the transfer standard calibrator to the station's nightly check line. Please see Section 5.3.1 Step 5 for how to connect the transfer standard to the station inlet.
2. Introduce zero air from the transfer standard calibrator to the analyzer. If the transfer standard calibrator is certified at the zero level by keying in 0.000 ppm (as opposed to just pressing "ZERO-ENTER") at the time of its test, then follow this method during an actual calibration. Be sure that excess supply flow at the probe inlet is 25 to 50% greater than analyzer flow (compare total flow readings on the analyzer and transfer standard calibrator).
3. Let the zero readings on the transfer standard calibrator and the analyzer stabilize and then wait an additional five minutes to confirm stabilization (this will be done with all transfer standard calibrator test points). Record the results on the calibration sheet. This is the pre-calibration zero air concentration reading.
4. Generate a precision level and introduce to the analyzer. This is the pre-calibration precision concentration reading.
5. Zero correct the precision levels from the transfer standard calibrator and analyzer. Calculate the % relative error (%RE) of the analyzer's responses.

Equation 11. Percent Relative Error

$$\frac{zc\ DAS - true[O_3]}{true[O_3]} * 100\% = \%RE$$

Where: zc DAS = zero corrected analyzer reading as read through the data logger.

True[O₃] = zero corrected transfer standard calibrator reading.

6. If the precision level error is < +/- 7.1% RE a full assessment audit is not required. If it equals or exceeds +/-7.1%RE, the assessment fails and is followed with a full five point plus zero calibration assessment audit (the same as a post-calibration assessment in section 5.3.3.3 below) before any adjustment or repairs are made to the analyzer. This is to characterize the out-of-spec condition fully, and the information will be used during data validation. Additionally, if the assessment fails, documentation of this failure in a Message to Central is required as described in Section 5.3.3.3 Step 10.

6.3.2 Calibration Adjustment

Introduction

After the pre-calibration audit, the analyzer is adjusted (calibrated) at the zero and precision level so that they most closely match the known concentrations put out by the transfer standard calibration system. After this is done, a five level plus zero multipoint test is reintroduced to characterize the analyzer response over the entire measurement range.

The recommended ranges for the multi-point calibration points are detailed in Table 3. As each calibration point is generated, the responses shown by the data logger should be compared to the calibrator value.

Table 3. Calibration Range Ozone Analyzers

Units	Parts per billion (ppb)
Calibration Scale	0 to 250 ppb
<u>Approximate Calibration Points</u>	
Level 1	240 ppb
Level 2	200 ppb
Level 3	150 ppb
Level 4	100 ppb
Level 5	60 ppb
Zero Level	0 ppb

Level 5 is the accepted precision level that is used to adjust the calibration of the analyzer with as little error as possible, along with the Zero Level. The procedure for performing the calibration is given below.

Procedure

1. To start the analyzer calibration adjustment, introduce zero air again to the analyzer and let the chart trace stabilize.

If the analyzer does not display zero for the concentration reading, on the analyzer's front panel navigate to the calibration menu, and calibrate the zero. Display concentration will go to 0.000. This is the calibration adjustment of the zero level.

2. Generate another precision level and introduce to the analyzer again. Let the analyzer stabilize.
3. Navigate to the calibration menu on the analyzer. Input zero corrected O₃ precision concentration as displayed by the transfer standard calibrator. This is the calibration adjustment of the precision level. The analyzer readings must be made as accurately as possible at the zero and precision levels.
4. Steps 1 thru 3 can be repeated if the calibration settings from the initial calibration or subsequent calibrations are not sufficiently accurate. This is accomplished by independently sending zero air and known test gas concentrations (10 to 20% of calibration full scale) to the analyzer to assess the accuracy of the calibration. If the results are not optimal, repeat steps 1 thru 5. Several attempts between the zero air and the test gas, along with calibration adjustments, may be required. Record the calibration results on the calibration sheet.
5. If any analog readings from the analyzer are taken by the data logger, press SETUP-MISC-D/A-CAL and use a DVM to calibrate the analog-to-digital converter. Adjust the D/A potentiometer R31 on the V/F card so that the DVM and the data logger readings match the front panel reading. If all readings are digital then this step may be skipped.

6.3.3 Post-Calibration Assessment

Introduction

The post-calibration assessment challenges the analyzer with five different test gas concentrations levels plus a zero to evaluate the accuracy of the new calibration. The assessment begins with a zero point followed by points at <20% (Level 4 - precision), >80% (Level 1 - span), ~60% (Level 2), and ~40% (Level 3). Results for these tests are used to evaluate the relative error at full scale. Concentration levels are generated as described in the pre-calibration assessment (5.3.3.1). The procedure for performing the post-calibration assessment is given below.

Procedure:

1. Generate zero air with the transfer standard calibrator and deliver to the analyzer. Record zero air results and all following test points on the calibration sheet.
2. Introduce a Level 1 concentration (greater than 80% full scale to the analyzer). Let it stabilize for at least five minutes. Record results on the calibration sheet.
3. Measure and generate three more O₃ concentrations that come in at approximately 70, 50, and 30% of full range. Introduce to the analyzer as above. Record the results on the calibration sheet.
4. Generate a final zero air to the analyzer and record the results. Calculate a least-squares linear regression between the known O₃ concentrations (including the zero point) as the ordinate and the zero corrected analyzer responses as the abscissa. Record slope, intercept, and correlation coefficient on the calibration

sheet. Also calculate, using this response curve, a %REFS (Equation 4) for a calibrated analyzer response given a known introduced concentration of exactly 90% of the full measurement range of the analyzer.

5. The criteria for a successful calibration is where all non-zero test points after the calibration adjustment show a <+/-2% full scale error from the final best fit regression calibration line. The precision level should be as close to 0% error as possible. If the post-calibration assessment begins to show a failure at any point, and repeating previous analyzer adjustments do not solve the problem, then maintenance is probably needed for the analyzer.

Equation 12. Relative Error at Full Scale

$$\frac{[(90\% \text{ full scale} * m) + i] - 90\% \text{ full scale}}{90\% \text{ full scale}} * 100 = \%REFS$$

where:

m = slope of response curve.

i = intercept of response curve.

90% full scale = 225 ppb

%REFS = Relative Error at Full Scale

6. Reattach the station calibrator supply line back to its external valve output.
7. Do another zero, span and precision routine like the one done before the calibration (Section 9.3.2). Record results on the calibration sheet and on the calibration sticker. These are the z/s/p values at time of calibration.
8. Record analyzer parameters, especially the new analyzer calibration settings, from the front panel display, on the calibration sticker and sheet.
9. Enable the analyzer. Record the MST time the instrument was brought back on line on the calibration sheet and on the station O₃ log. Put the calibration sticker on a surface near the analyzer so that it is easily read.
10. Enter the calibration results in a “message to central”. On the data logger message window to Central type and send:

O₃ cal, z=xxx, s=yyy, p=zzz, aaa

Where:

xxx= zero reading of the station calibrator through the data logger.

yyy= span reading of the station calibrator through the data logger.

zzz=precision reading of the station calibrator through the data logger.

aaa=initials of calibration specialist.

This is a message through the data logger to the GMM unit worker responsible for tracking calibrations in the ZSPTracking database. This message is permanently stored in the AirVision system and information from this message is manually inputted into the ZSPTracking database.

In the event of a failed precalibration audit or assessment, a separate message is sent to Central in the form of

O3 CAL FAILED AUDIT,

(in all CAPS) followed by a general description in regular text and the calibrator's initials. This is to highlight important cal/audit information for the purposes of data validation.

11. Record analyzer parameters and calibration and maintenance actions on the station O₃ log.

7 CAPS NO2 CALIBRATION PROCEDURE

7.1 Calibration Train Setup

1. Connect the clean air supply directly to the zero air input of the calibrator (Figure 1).
2. Before the NO cal gas cylinder is connected to the calibrator, its line and regulator must be purged at least three times. This is done in order to remove all ambient air from the regulator. (Ambient air in the regulator can dilute the NO and bias the calibration results and introduce ambient contaminants that interact with the NO.) The following describes the line and regulator purging action:
 - a. Open the regulator and cylinder valves. The closed quick connect will keep the cal gas from escaping
 - b. Close the cylinder valve.
 - c. Push the end of the quick connect nozzle against a clean, flat surface to partially release the pressure within the regulator and line. Carefully watch the two regulator gauges and do not let either of them fall to zero. A positive pressure compared to ambient must be kept so that room air will not surge back into the line and regulator. To stop the release of cal gas, pull the quick connect nozzle away from the flat surface.
 - d. Repeat Steps a through c two times.
 - e. Open the cylinder valve to recharge the regulator and line to full pressure as indicated by the two regulator gauges.
3. After purging, connect the NO cal gas regulator line directly to the cal gas input of the dilution calibrator. Adjust delivery pressure between 20 to 30 psi.
4. Connect a Teflon line to the exit port of the transfer standard calibrator. The length of this line should be of sufficient length to reach from the transfer standard (TS) calibrator to the back of the station (Stat) calibrator or the station SO₂ analyzer. This is the transfer standard calibrator supply line (supply line). Leave this other end of this line unconnected end for now.
5. The introduction of test gas to the analyzer can be performed in one of two ways depending upon how the station calibrator is configured for the nightly performance tests. The transfer standard calibrator should be configured similarly to the station calibrator if possible. If the station calibrator is configured to introduce test gas through the probe (TTP) then the transfer standard calibrator should be configured likewise. The same is true if the station calibrator is configured to the back of the analyzer (BOA). In most situations the site calibration line can be removed directly from the back of the station calibrator and connected to the transfer standard calibrator output line with a Teflon union. If the a solenoid manifold is used external to the station calibrator to direct test gas TTP to individual analyzers, then it is acceptable to connect the transfer standard output line to the station TTP calibration line on the output side of the solenoid. Simply disconnect the TTP calibration line from the output side of the solenoid and connect it to the transfer standard output with a Teflon union. This method eliminates the need to activate the solenoid for the entire length of the calibration. An exception to the above methods is if the station calibrator is connected directly

to a calibration port on the back of the analyzer. In this situation the sample line is removed from the sample inlet port on the back of the analyzer and the transfer standard output line is connected directly to the sample inlet port through the use of a Teflon tee. A 12" (or >) length of clean Teflon is connected to the empty leg of the tee that will be used as a vent to bleed off excess test gas that is introduced to the analyzer by the transfer standard calibrator to prevent back pressure in the analyzer.

IMPORTANT NOTE: Since the CAPS analyzer measures only NO₂, there are no internal fully calibrated NO and NO_x measurements to use to calculate the true NO₂ concentration being titrated and presented to the analyzer. Since a calibration of the CAPS requires known true NO₂ concentrations, an independent, collocated NO_x analyzer will always be present along with the CAPS in the station in order to determine true NO₂ (see relevant NO_x calibration sections in this QAPP document).

In practice, this usually means that a calibration of the collocated NO_x analyzer is done just before and concurrently with the CAPS analyzer in order for the calibration specialist to have known NO and NO_x concentration readings from which to titrate and calculate known true NO₂ levels.

Though not mentioned in the text below, first the NO_x analyzer's NO and NO_x channels are fully calibrated before calibration adjustment of the CAPS. Pre-calibration audit and post-calibration assessment points are alternated between the NO_x and CAPS analyzers by shifting the calibration supply line between the two.

All transfer standard (TS) calibrator generated NO₂ levels used to challenge the CAPS in the following assumes newly and fully calibrated NO and NO_x channels on the collocated NO_x analyzer.

7.2 Pre-calibration Zero, Span, and Precision Routine

This routine is done before there is adjustment to the analyzer to help correlate the preceding automatic zeros and spans (z/s) and precisions (p) with the pre-calibration audit responses. It is also done at the end of the calibration procedure to generate new official z/s/p values for the following sampling period until the next calibration. In practice these routines are started just before and after any calibration / audit to allow time to set up or tear down the calibration equipment while they run their course.

If the analyzer is communicating with the data logger over an analog connection, connect a digital volt meter (DVM) or digital chart recorder to the analog output of the monitor or the analog input of the data logger according to ease of accessibility. This step should not be performed if the analyzer is communicating with the data logger over a digital connection (GSI or Modbus).

IMPORTANT NOTE: The following procedure must be performed for both the collocated NO_x analyzer and the CAPS analyzer. This can be performed by running the procedure twice, once for each analyzer, or once by splitting the test gas stream and directing half to each analyzer, assuming the test gas volume is sufficient to adequately supply each analyzer the required amount, ensuring at least 500 ml/min excess flow. The collocated NO_x analyzer is used to determine NO₂ Actual (Actual Concentration in Equation 1). This value is then compared to the value generated by the CAPS analyzer (t).

1. Take the CAPS and collocate NO_x analyzer channels offline.
2. Start an automatic precision/zero routine. This is done by a command through the data logger (See data logger section in this QAPP document). Allow this routine to run fully until its automatic ending. During the run make sure that all readings from the front panels of the Stat calibrator and CAPS analyzer match the numbers seen in the data logger. Record the final reported numbers on the calibration (cal) sheet. A precision is done before a span because the CAPS analyzer is more sensitive to conditioning effects at this level, and the purpose of the pre-cal precision is to emulate the midnight precisions as closely as possible.

3. Start an automatic span/zero routine as done with step two with the precision. If a second auto zero is not needed, the automatic span/zero routine can be aborted through the data logger after the span phase is finished; but if done so, the last five minute readings of the Stat calibrator and analyzer during span must be manually averaged as no report will be provided by the data logger.
4. Zero-correct the data logger precision span test level (t) results.

$$t - \text{zero value} = \text{zero corrected test level (zct)}$$

5. Calculate the percentage relative error (%RE) of the two zct's and record on the calibration sheet.

Equation 13. Percent Relative Error

$$\frac{zct - \text{true}[NO_2]^*}{\text{true}[NO_2]^*} * 100\% = \%RE$$

*true[NO₂] is the concentration of the test gas as reported by the station calibrator through the data logger. true[NO₂] is determined by the difference in NO between the NO only phase and the gas phase titration phase from the collocated NO_x analyzer.

The precalibration span and precision plus station zero can also be run manually through the data logger, but the calibration specialist must be careful to emulate automatic phase times so that conditioning effect differences between previous midnight auto spans and precisions and this pre-calibration span and precision can be minimized. For some diagnostic purposes a manual running of the precision and span is sometimes more useful and practical than using the automatic routines. The manually triggering of relays through the data logger is non-routine and the procedure to perform this task is not included in this SOP. Contact the Data Manager to attain information on how to perform this task.

7.3 Pre-Calibration Audit, Calibration Adjustment and Post-Calibration Assessment

7.3.1 Pre-Calibration Audit Procedure

Introduction

From the transfer standard calibrator set up introduce zero and precision levels (including a separate titrated NO₂ precision level) test gas to the analyzer. Calculate %RE for the zero corrected precision level results. If this exceeds +/- 10 %RE, follow with a full five point (intervening with five titrated NO₂ levels) plus zero calibration assessment audit (the same as a post-calibration assessment in method below) before any adjustment is made to the analyzer. This assessment audit is the same as described below in section 6.3.3.3 Post-Calibration Assessment. This is to characterize the out-of-spec condition fully, and the information will be used during data validation.

If the analyzer fails the five point assessment audit then repairs and calibration of the instrument are done as soon as possible after the audit. If the repairs required are beyond the resources of the calibration specialist then the monitoring technician for that station is notified immediately. Proceed to the calibration adjustment procedure in Section 6.3.3.2 if the pre-calibration audit results less than +/- 10 %RE. Failed pre-calibration assessment audits require an electronic message in the data logger that will to be use for data validation purposes. The procedure for performing the pre-calibration audit is given below.

Procedure

IMPORTANT NOTE: The following procedure must be performed for both the collocated NO_x analyzer and the CAPS analyzer. This can be performed by running the procedure twice, once for each analyzer, or once by splitting the test gas stream and directing half to each analyzer, assuming the test gas volume is sufficient to adequately supply each analyzer the required amount, ensuring at least 500 ml/min excess flow. The collocated NO_x analyzer is

used to determine NO₂ Actual (Actual Concentration in Equation 1). This value is then compared to the value generated by the CAPS analyzer (t).

1. Generate a zero point (Level 5) from the TS calibrator. If a TAPI 700x calibrator with certified MFCs is used then simply request the desired NO/NO₂ concentration level or ZERO point. Refer to the calibrator's operating manual for procedures on how to generate manual concentrations from the calibrator (Teledyne-API, 2009). Make sure the correct port and NO₂ tank concentration are programmed into the calibrator.
2. Let the zero dilution airflow in the calibrator stabilize. This should usually take less than five minutes.
3. Connect the transfer standard calibrator to the analyzer's inlet system. This connection can be made several ways depending upon how the station calibrator is configured with the inlet system. Please see Section 6.3.1 Step 5 for a more detailed description of the setup options.
4. Send zero air through the probe to the analyzer from the TS calibrator. Be sure that excess supply flow at the probe is 10 to 50% greater than analyzer flow (compare total flow readings on the analyzer and TS calibrator).
5. Allow at least five minutes after the analyzer has stabilized. Record the NO,NO₂,NO_x (collocated NO_x) and NO₂ (CAPS) analyzer results on the calibration sheet. This is the pre-calibration zero air concentration reading.
6. Generate a test precision concentration of NO that is approximately 20-80 % higher than the desired NO₂ concentration. Precision levels are typically between 10 and 20% of the calibration range of the analyzer. The MFCs in the TS calibrator should not be used below 10% or above 90% of their full scale for older TAPI 700xs. Some of the newer MFCs in newer TAPI 700xs are capable of using an upper range of 99% of their full scale, but if in doubt use the more constricted range when generating a concentration while keeping in mind that an excess of gas must be provided to the probe. Record the NO,NO₂,NO_x (collocated NO_x) and NO₂ (CAPS) analyzer results on the calibration sheet.
7. Titrate from this NO precision the NO₂ precision level immediately afterwards. NOTE: When titrating from a given NO level, do not leave less than 20% or more than 80% of the original NO concentration. This will minimize back reactions between NO and NO₂. Allow at least five minutes after a stable response from the analyzer is achieved. Record the NO,NO₂,NO_x (collocated NO_x) and NO₂ (CAPS) analyzer results on the calibration sheet. Perform a zero correction of the raw results.

Calculate the relative error of the analyzer's response

Equation 14. Percent Relative Error

$$\frac{\text{Analyzer Reading} / (DAS) - \text{true}[NO_2]}{\text{true}[NO_2]} * 100\% = \%RE$$

Note: NO₂ Actual (true[NO₂]) is determined by the difference in NO between the NO only phase and the gas phase titration phase from the collocated NO_x analyzer.

8. If the precision level error is < +/- 10% RE a full assessment audit is not required, proceed to 6.3.3.2. If it equals or exceeds +/-10%RE, follow with a full four point plus zero calibration assessment audit (the same as a post-calibration assessment in section 9.3.3.3 below) before any adjustment or repairs are made to the analyzer. This is to characterize the out-of-spec condition fully, and the information will be used during data validation. Additionally, if the assessment fails, documentation of this failure in a Message to Central is required as described in Section 6.3.3.3 Step 10.

7.3.2 Calibration Adjustment

Introduction

After the pre-calibration audit, the analyzer is adjusted (calibrated) at the zero and precision level so that the analyzer most closely matches the known concentrations produced by the calibration system. After this is done, a five level plus zero multipoint calibration assessment (6.3.3.1) is reintroduced to characterize the analyzer response over the entire measurement range. The recommended ranges for the multi-point calibration points are detailed in Table 4. As each calibration point is generated, the responses shown by the data logger should be compared to the newly calibrated collocated NO_x analyzer reading.

Table 4. Calibration Ranges for Oxides of Nitrogen Analyzers

Units	Parts per billion (ppb)
Calibration Scale	0 to 500 ppb
Compressed gas cylinder	15-25 ppm*
* Based on calibrator mfc ranges: gas1 = 50ml/min, gas2 = 100 ml/min, dil = 10 or 20 l/min	
<u>Calibration points</u>	
Level 1	350-500 ppb
Level 2	250–350 ppb
Level 3	150–250 ppb
Level 4	50–150 ppb
Level 5 - zero	0 ppb

Level 4 is the accepted precision level that is used to adjust the calibration of the analyzer with as little error as possible (along with Level 5, or the zero level). The procedure for performing the calibration adjustment is given below.

Procedure:

IMPORTANT NOTE: Actual NO₂ values used during in the analyzer calibration procedure below are most commonly determined from a collocated NO_x analyzer. Other methods may also prove to be feasible, such as utilizing the GPT-PS function in the TAPI 700 calibrator or by direct dilution of a compressed NO₂ gas standard. Currently, the use of a collocated NO_x analyzer has been proven to be the most reliable method and is used in the below procedure. If a collocated NO_x analyzer is used, calibration test gas must be delivered to both analyzers. This can be performed by running the procedure twice, once for each analyzer, or once by splitting the test gas stream and directing half to each analyzer, assuming the test gas volume is sufficient to adequately supply each analyzer the required amount, ensuring at least 500 ml/min excess flow.

1. To start the analyzer calibration adjustment, introduce zero air again to the analyzer and let the chart trace stabilize.

If the channel does not display zero for the concentration reading, on the analyzer’s front panel navigate to the calibration menu and zero. Display concentration will go to 0.000. This is the calibration adjustment of the zero level.

2. Generate another precision level and introduce to the analyzer again. Let the chart trace stabilize.

3. Navigate to the calibration menu and input NO₂ precision concentration as displayed by the newly and fully calibrated collocated NO_x analyzer*. In the calibration menu initiate the calibrate span option. This is the calibration adjustment of the precision level.

*If the NO_x channel reading on the collocated NO_x analyzer is known to be off, as in a QA audit on the NO_x analyzer (covered in the QA section of this QAPP document) and no calibration is allowed, or in some calibration diagnostic actions, calculate the %RE of the NO_x channel and use this to proportionately correct the NO₂ reading to true NO₂.

4. Steps 1 thru 3 can be repeated if the calibration settings from the initial calibration or subsequent calibrations are not sufficiently accurate. This is accomplished by independently sending zero air and known test gas concentrations (10 to 20% of calibration full scale) to the analyzer to assess the accuracy of the calibration. If the results are not optimal, repeat steps 1 thru 3. Several jumps between the zero air and the test gas, along with calibration adjustments, may be required. Record the calibration results on the calibration sheet.

7.3.3 Post-Calibration Assessment

Introduction

The post-calibration assessment challenges the analyzer with five different test gas concentrations levels plus a zero to evaluate the accuracy of the new calibration. The assessment begins with a zero point followed by points at <20% (Level 4 - precision), >80% (Level 1 - span), ~60% (Level 2), and ~40% (Level 3). Results for these tests are used to evaluate the relative error at full scale. Concentration levels are generated as described in the pre-calibration assessment (6.3.3.1). Note: Generated NO concentrations should be at least 20% greater than the desired NO₂ target concentrations. This is to allow for a 20% NO residual that is required during the gas phase titration phase. It is acceptable to generate and evaluate the NO/NO_x channels on the collocated NO_x analyzer at concentration levels higher than the desired NO₂ concentration levels. The procedure for performing the post-calibration assessment is given below.

Procedure

1. Generate zero air and deliver it to both the collocated NO_x and CAPS analyzers. Record the NO, NO₂, NO_x results for the collocated NO_x analyzer and NO₂ results on the calibration sheet.
2. Generate an NO test gas concentration at >20% above the NO₂ Level-4 precision target concentrations range and introduce it to the analyzer. Note results for all analytes as in Step 1. Follow this by the generation an NO₂ test gas concentration at the Level-4 precision target concentration using gas phase titration. Note results for all analytes as in Step 1.
3. Repeat Step 2 for the Level-1, Level-2 and Level-3 test gas concentration ranges as describe in Table 1 above.
4. Send a final zero air to the analyzer and record the results as in Step 1. Calculate a least-squares linear regression between the true NO₂ concentrations (including the zero point), as determined by the collocated NO_x analyzer, as the ordinate and the zero corrected CAPS analyzer responses as the abscissa. Record slope, intercept, and correlation coefficient on the calibration sheet. Also calculate, using this response curve, a %REFS for a calibrated analyzer response given a known introduced concentration of exactly 90% of the full measurement range of the analyzer.
5. The criteria for a successful calibration is where all non-zero test points after the calibration adjustment show a <+/-2% full scale error from the final best fit regression calibration line. The precision level should be as close to 0% error as possible. If the post-calibration assessment begins to show a failure at any point, and repeating previous analyzer adjustments do not solve the problem, then maintenance is probably needed for the analyzer.

Equation 15. Relative Error at Full Scale

$$\frac{[(90\% \text{ full scale} * m) + i] - 90\% \text{ full scale}}{90\% \text{ full scale}} * 100 = \%REFS$$

where:

m = slope of response curve.

i = intercept of response curve.

90% full scale = 900 ppb (calibration full scale 0-1000 ppb)

%REFS = Relative Error at Full Scale

6. Reattach the station calibrator's supply line back to its solenoid valve on the span panel.
7. Do another zero, span and precision routine like the one done before the calibration (Section 6.3.2). Record results on the calibration sheet and on the calibration sticker. These are the z/s/p values at time of calibration.
8. From the collocated NO_x/NO_y analyzer's final z/s/p results, calculate % of NO_x result that is due to NO₂ residual concentration in the NO station span bottle. This value is the relative concentration of NO₂ to NO in the bottle.

$$\frac{(NO_x - NO)}{NO_x} * 100\% = \%NO_2$$

where:

NO_x = NO_x result during final span on the collocated NO_x/NO_y analyzer.

NO = NO result during final span on the collocated NO_x/NO_y analyzer.

%NO₂ = % residual NO₂ compared to NO concentration in station span bottle.

If the %NO₂ is >= 2%, the station span bottle will need to be changed out and the relevant personnel contacted.

9. Record analyzer parameters, especially the new analyzer calibration settings (slope & offset), from the front panel display on the calibration sticker and sheet.
10. Enable the CAPS NO₂ channel and the collocated NO_x analyzer NO/NO₂/NO_x channels. Record the MST time the instrument was brought back on line on the calibration sheet and on the station CAPS NO₂ and NO_x analyzer logs. Put the calibration sticker on a surface near the analyzer so that it is easily read.
11. Enter the calibration results in a "message to central". On the data logger message window to Central type and send:

NO₂ CAPS cal, z=xxx, s=yyy, p=zzz, aaa

Where:

xxx=post-calibration zero reading

yyy=post-calibration span reading

zzz=post-calibration precision reading

aaa=calibration specialist's initials

%NO₂ (percentage of NO₂ residual compared to NO concentration in station span bottle, calculated from NO_x/NO_y analyzer calibration)

Plus type the calibration specialist's initials and any comments that are felt relevant such as non-routine actions or maintenance done.

This is a message through the data logger to the GMM unit worker responsible for tracking calibrations in the ZSPTracking database. This message is permanently stored in the AirVision system and information from this message is manually inputted into the ZSPTracking database.

In the event of a failed precalibration audit or assessment, a separate message is sent to Central in the form of

CAPS CAL FAILED AUDIT,

(in all CAPS) followed by a general description in regular text and the calibrator's initials. This is to highlight important cal/audit information for the purposes of data validation.

12. Record analyzer parameters and calibration and maintenance actions on the station NO₂ log.

8 NO_x CALIBRATION PROCEDURE

8.1 Calibration Train Setup

1. Connect the clean air supply directly to the zero air input of the calibrator (Figure 1).
2. Before the NO cal gas cylinder is connected to the calibrator, its line and regulator must be purged at least three times. This is done in order to remove all ambient air from the regulator. (Ambient air in the regulator can dilute the NO and bias the calibration results and introduce ambient contaminants that interact with the NO.) The following describes the line and regulator purging action:
 - a. Open the regulator and cylinder valves. The closed quick connect will keep the cal gas from escaping
 - b. Close the cylinder valve.
 - c. Push the end of the quick connect nozzle against a clean, flat surface to partially release the pressure within the regulator and line. Carefully watch the two regulator gauges and do not let either of them fall to zero. A positive pressure compared to ambient must be kept so that room air will not surge back into the line and regulator. To stop the release of cal gas, pull the quick connect nozzle away from the flat surface.
 - d. Repeat Steps a through c two times.
 - e. Open the cylinder valve to recharge the regulator and line to full pressure as indicated by the two regulator gauges.
3. After purging, connect the NO cal gas regulator line directly to the cal gas input of the dilution calibrator. Adjust delivery pressure between 20 to 30 psi.
4. Connect a Teflon line to the exit port of the transfer standard calibrator. The length of this line should be of sufficient length to reach from the transfer standard (TS) calibrator to the back of the station (Stat) calibrator or the station NO_x analyzer. This is the transfer standard calibrator supply line (supply line). Leave this other end of this line unconnected end for now.

5. The introduction of test gas to the analyzer can be performed in one of two ways depending upon how the station calibrator is configured for the nightly performance tests. The transfer standard calibrator should be configured similarly to the station calibrator if possible. If the station calibrator is configured to introduce test gas through the probe (TTP) then the transfer standard calibrator should be configured likewise. The same is true if the station calibrator is configured to the back of the analyzer (BOA). In most situations the site calibration line can be removed directly from the back of the station calibrator and connected to the transfer standard calibrator output line with a Teflon union. If the a solenoid manifold is used external to the station calibrator to direct test gas TTP to individual analyzers, then it is acceptable to connect the transfer standard output line to the station TTP calibration line on the output side of the solenoid. Simply disconnect the TTP calibration line from the output side of the solenoid and connect it to the transfer standard output with a Teflon union. This method eliminates the need to activate the solenoid for the entire length of the calibration. An exception to the above methods is if the station calibrator is connected directly to a calibration port on the back of the analyzer. In this situation the sample line is removed from the sample inlet port on the back of the analyzer and the transfer standard output line is connected directly to the sample inlet port through the use of a Teflon tee. A 12" (or >) length of clean Teflon is connected to the empty leg of the tee that will be used as a vent to bleed off excess test gas that is introduced to the analyzer by the transfer standard calibrator to prevent back pressure in the analyzer.

8.2 Pre-calibration Zero, Span, and Precision Routine

This routine is done before there is adjustment to the analyzer to help correlate the preceding automatic zeros and spans (z/s) and precisions (p) with the pre-calibration audit responses. It is also done at the end of the calibration procedure to generate new official z/s/p values for the following sampling period until the next calibration. In practice these routines are started just before and after any calibration / audit to allow time to set up or tear down the calibration equipment while they run their course.

If the analyzer is communicating with the data logger over an analog connection, connect a digital volt meter (DVM) or digital chart recorder to the analog output of the monitor or the analog input of the data logger according to ease of accessibility. This step should not be performed if the analyzer is communicating with the data logger over a digital connection (GSI or Modbus).

1. Take the NO/NO₂/NO_x analyzer channels offline.
2. Start an automatic precision/zero routine. This is done by a command through the data logger. Allow this routine to run fully until its automatic ending. During the run make sure that all concentration readings (NO/NO₂/NO_x) from the front panels of the station calibrator and NO_x analyzer match the numbers seen in the data logger. Record the final reported numbers on the calibration (cal) sheet. A precision is done is done before a span because the NO_x analyzer is more sensitive to conditioning effects at this level, and the purpose of the pre-cal precision is to emulate the midnight precisions as closely as possible. Note that there will be two parts to the precision proper, a NO/NO_x component without titration to assess those two channels, and then a titration of the NO gas to NO₂. The span will also have these two components.
3. Start an automatic span/zero routine as done with step two with the precision. If a second auto zero is not needed, the automatic span/zero routine can be aborted through the data logger after the span phase is finished; but if done so, the last five minute readings of the station calibrator and analyzer during span must be manually averaged as no report will be provided by the data logger.
4. Zero-correct the data logger precision span test level (t) results for all channels (NO/NO₂/NO_x).

$$t - \text{zero value} = \text{zero corrected test level (zct)}$$

5. Calculate the percentage relative error (%RE) of the two zct's and record on the calibration sheet.

Equation 16. Percent Relative Error

$$\frac{zct - true[NO, NO_2, NO_x]^*}{true[NO, NO_2, NO_x]^*} * 100\% = \%RE$$

*True [NO,NO₂,NO_x] is the concentration of the test gases as reported by the station calibrator through the data logger. True [NO₂] is determined by the difference in NO between the NO only phase and the gas phase titration phase.

The pre-calibration span and precision plus station zero can also be run manually through the data logger, but the calibration specialist must be careful to emulate automatic phase times so that conditioning effect differences between previous midnight auto spans and precisions and this pre-calibration span and precision can be minimized. For some diagnostic purposes a manual running of the precision and span is sometimes more useful and practical than using the automatic routines. The manually triggering of relays through the data logger is non-routine and the procedure to perform this task is not included in this SOP. Contact the Data Manager to attain information on how to perform this task.

8.3 Pre-Calibration Audit, Calibration Adjustment and Post-Calibration Assessment

8.3.1 Pre-Calibration Audit Procedure

Introduction

From the transfer standard calibrator set up introduce zero and precision levels (including a separate titrated NO₂ precision level) test gas to the analyzer. Calculate %RE for the zero corrected precision level results. If this exceeds +/- 10 %RE, follow with a full five point (intervening with five titrated NO₂ levels) plus zero calibration assessment audit (the same as a post-calibration assessment in method below) before any adjustment is made to the analyzer. This assessment audit is the same as described below in section 7.3.3.3 Post-Calibration Assessment. This is to characterize the out-of-spec condition fully, and the information will be used during data validation.

If the analyzer fails the five point assessment audit then repairs and calibration of the instrument are done as soon as possible after the audit. If the repairs required are beyond the resources of the calibration specialist then the monitoring technician for that station is notified immediately. Proceed to the calibration adjustment procedure in Section 7.3.3.2 if the pre-calibration audit results less than +/- 10 %RE. Failed pre-calibration assessment audits require an electronic message in the data logger that will to be used for data validation purposes. The procedure for performing the pre-calibration audit is given below.

Procedure

1. Generate a zero point (Level 5) from the transfer standard calibrator. If a TAPI 700x calibrator with certified MFCs is used then simply request the desired NO/ NO₂ concentration level or ZERO point. Refer to the calibrator's operating manual for procedures on how to generate manual concentrations from the calibrator (Teledyne-API, 2009).
2. Let the zero dilution airflow in the calibrator stabilize. This should usually take less than five minutes.
3. Connect the transfer standard calibrator to the analyzer's inlet system. This connection can be made several ways depending upon how the station calibrator is configured with the inlet system. Please see Section 7.3.1 Step 5 for a more detailed description of the setup options.
4. Send zero air through the probe to the analyzer from the transfer standard calibrator. Be sure that excess supply flow at the probe is 10 to 50% greater than analyzer flow (compare total flow readings on the analyzer and transfer standard calibrator).
5. Allow at least five minutes after the analyzer has stabilized. Record the NO,NO₂,NO_x results on the calibration sheet. This is the pre-calibration zero air concentration reading.

6. Generate a test precision concentration of NO that is approximately 20-85 % higher than the desired NO₂ concentration. Precision levels are typically between 10 and 20% of the calibration range of the analyzer. The MFCs in the transfer standard calibrator should not be used below 10% or above 90% of their full scale for older TAPI 700xs. Some of the newer MFCs in newer TAPI 700xs are capable of using an upper range of 99% of their full scale, but if in doubt use the more restrictive range when generating a concentration while keeping in mind that an excess of gas must be provided to the probe. Record the NO,NO₂,NO_x results on the calibration sheet.
7. Titrate from this NO precision the NO₂ precision level immediately afterwards. NOTE: When titrating from a given NO level, do not leave less than 20% or more than 80% of the original NO concentration. This will minimize back reactions between NO and NO₂. Allow at least five minutes after a stable response from the analyzer is achieved. Record the NO,NO₂,NO_x results on the calibration sheet. Apply a zero correction to the raw results.

Calculate the relative error of the analyzer’s response

Equation 17. Percent Relative Error

$$\frac{\text{Analyzer Reading} / (\text{DAS}) - \text{true}[\text{NO}, \text{NO}_2, \text{NO}_x]}{\text{true}[\text{NO}, \text{NO}_2, \text{NO}_x]} * 100\% = \%RE$$

8. Percent relative error is determined for each channel on the analyzer (NO,NO₂,NO_x). If the precision level error for each channel is < +/- 10% RE a full assessment audit is not required, proceed to 7.3.3.2. If it equals or exceeds +/-10%RE, follow with a full four point plus zero calibration assessment audit (the same as a post-calibration assessment in section 7.3.3.3 below) before any adjustment or repairs are made to the analyzer. This is to characterize the out-of-spec condition fully, and the information will be used during data validation. Additionally, if the assessment fails, documentation of this failure in a Message to Central is required as described in Section 7.3.3.3 Step 10.

8.3.2 Calibration Adjustment

Introduction

After the pre-calibration audit, the analyzer is adjusted (calibrated) at the zero and precision level so that the analyzer most closely matches the known concentrations produced by the calibration system. After this is done, a five level plus zero multipoint calibration assessment (7.3.3.3) is reintroduced to characterize the analyzer response over the entire measurement range. The calibration points are generated by diluting a higher concentration of NO from a NIST-traceable calibration gas to a target concentration. The recommended ranges for the multi-point calibration points are detailed in Table 5. As each calibration point is generated, the responses shown by the data logger should be compared to the calibrator value.

Table 5. Calibration Ranges for Oxides of Nitrogen Analyzers

Units	Parts per billion (ppb)	Parts per billion (ppb)
Calibration Scale	0 to 1000 ppb	0 to 500 ppb
Compressed gas cylinder	15-25 ppm*	15-25 ppm*
* Based on calibrator mfc ranges: gas1 = 50mL/min, gas2 = 100 mL/min, dil = 10 or 20 L/min		
<u>Calibration points</u>		
Level 1	750-1000 ppb	350-500 ppb

Level 2	500–750 ppb	250–350 ppb
Level 3	250–500 ppb	150–250 ppb
Level 4	50–250 ppb	50–150 ppb
Level 5 - zero	0 ppb	0 ppb

Level 4 is the accepted precision level that is used to adjust the calibration of the analyzer with as little error as possible (along with Level 5, or the zero level).

8.3.2.1 Molybdenum Converter Models

1. To start the analyzer calibration adjustment, introduce zero air again to the analyzer and let the chart trace stabilize.

If any of the three channels do not display zero for the concentration reading, on the analyzer’s front panel navigate to the calibration menu, calibrate zero. Display concentration will go to 0.000. This is the calibration adjustment of the zero level.

2. Generate another precision level and introduce to the analyzer again. Let the chart trace stabilize.
3. TAPI 200x: Navigate to the calibration menu, calibrate span, and input NO and NO_x precision concentration as displayed by the transfer standard calibrator. Press ENTER. This is the calibration adjustment of the precision level.

TAPI 200E: To auto calibrate analog outputs go to DIAG menu, then ANALOG I/O CONFIGURATION. Press ENTER. On AOUTS CALIBRATED menu, press ENTER. A YES signal will show auto calibration completed. To adjust analog output offsets, from ANALOG I/O CONFIGURATION menu, press ENTER.

4. Press SET until CONC_OUT_X:IV, CAL (where X=output channel under adjustment) appears. Press EDIT. Press SET until CONC_OUT_X REC OFS:O mV appears. Press EDIT and then enter channel offset value in mV
5. Send zero air again to the analyzer. Let it stabilize for at least five minutes. Readjust the zero display value if necessary and repeat steps 1, 2, and 3 and then come back to this step. Several jumps between the zero air and the precision level, along with calibration adjustments, may be required.
6. If the NO_x channel changes from its untitrated level during an NO₂ input during titration, then the analyzer’s electronic Converter Efficiency (a correction constant in memory) may need to be adjusted. Send about a 60% full scale NO into the analyzer and note the NO_x reading. Off of this same high level NO concentration, titrate a high level NO₂ (keeping in mind the 15 and 85% titration constraints). Note how much the NO_x channel changes. In the analyzer’s CAL menu go to the NO₂ CONC. Take the real time NO₂ reading and correct this by how much the NO_x channel changed between no-titration and titration. (e.g. if the NO_x channel went up 3ppb during titration, then correct the real time NO₂ reading by subtracting 3ppb from it) Enter this corrected NO₂ value in the NO₂ CONC field and press ENTER. The new Converter Efficiency will be calculated automatically and a new correction constant stored in memory. NOTE: if the new CE is less than 97.5% as read in the menu, then the calibration will need to be stopped and maintenance on the analyzer performed.
7. Steps 1 thru 6 can be repeated if the calibration settings from the initial calibration or subsequent calibrations are not sufficiently accurate. This is accomplished by independently sending zero air and known test gas concentrations (10 to 20% of calibration full scale) to the analyzer to assess the accuracy of the calibration. If the results are not optimal, repeat steps 1 thru 6. Several jumps between the zero air and

the test gas, along with calibration adjustments, may be required. Record the calibration results on the calibration sheet.

8.3.2.2 Photolytic Converter Models

1. To start the analyzer calibration adjustment, introduce zero air again to the analyzer and let the chart trace stabilize.
2. If any of the three channels do not display zero for the concentration reading, on the analyzer's front panel press CAL. ZERO will appear. Press this. Display concentration will go to 0.000. This is the calibration adjustment of the zero level.
3. Generate another precision level and introduce to the analyzer again. Let the chart trace stabilize.
4. Press Cal. CONC will appear. Press this. NO SPAN CONC: XXX.X CONC will appear. Using buttons, input NO and NO_x precision concentration as displayed by the transfer standard calibrator. Press ENTER. This is the calibration adjustment of the precision level.
5. Press SET until CONC_OUT_X:1V, CAL (where X=output channel under adjustment) appears. Press EDIT. Press SET until CONC_OUT_X REC OFS:0 mV appears. Press EDIT and then enter channel offset value in mV
6. Steps 1 thru 5 can be repeated if the calibration settings from the initial calibration or subsequent calibrations are not sufficiently accurate. This is accomplished by independently sending zero air and known test gas concentrations (10 to 20% of calibration full scale) to the analyzer to assess the accuracy of the calibration. If the results are not optimal, repeat steps 1 thru 5. Several jumps between the zero air and the test gas, along with calibration adjustments, may be required. Record the calibration results on the calibration sheet.
7. If the NO_x channel changes from its untitrated level during an NO₂ input during titration, then the analyzer's two (A and B) electronic Converter Efficiency settings may need to be adjusted. The A CE is the low level correction factor for converter efficiency, and the B CE is for the high part of the range.
8. Send about a 60%full scale NO into the analyzer and note the NO_x reading. Off of this same high level NO concentration, titrate a high level NO₂ (keeping in mind the 15 and 85% titration constraints). Note how much the NO_x channel changes.
9. Take the real time NO₂ reading and correct this by how much the NO_x channel changed between no-titration and titration. (e.g. if the NO_x channel went up 3ppb during titration, then correct the real time NO₂ reading by subtracting 3ppb from it)
10. Enter this corrected NO₂ value into the NO₂ B menu of the CAL>CONC>CONV menu and press ENTER. Exit to SETUP and allow the readings to stabilize.
11. Press the CALB button in the CAL>CONC>CONV menu.
12. Press CAL and then ENTER. This is the actual calibration adjustment, and Point B CE value should have changed. Press EXIT until back to the SETUP menu.
13. Deliver a low level NO in the precision range to the analyzer. Note the NO_x as before, and then titrate a precision level NO₂ off of this. Find a corrected NO₂ as before from the change in the NO_x value.
14. Enter the corrected NO₂ value calculated into the NO₂A menu of the CAL>CONC>CONV menu and press ENTER. Exit to SETUP and allow the readings to stabilize.

15. Press the CALA button in the CAL>CONC>CONV menu.
16. Press CAL and then ENTER. This is the actual calibration adjustment, and Point A CE value should have changed. Press EXIT until back to the SETUP menu.

8.3.3 Post-Calibration Assessment

Introduction

The post-calibration assessment challenges the analyzer with five different test gas concentrations levels plus a zero to evaluate the accuracy of the new calibration. The assessment begins with a zero point followed by points at <20% (Level 4 - precision), >80% (Level 1 - span), ~60% (Level 2), and ~40% (Level 3). Results for these tests are used to evaluate the relative error at full scale. Concentration levels are generated as described in the pre-calibration assessment (7.3.3.1). Note: Generated NO concentrations should be at least 20% greater than the desired NO₂ target concentrations. This is to allow for a 20% NO residual that is required during the gas phase titration phase. It is acceptable to generate and evaluate the NO/NO_x channel at concentration levels slightly higher than the desired NO₂ concentration levels. The procedure for performing the post-calibration assessment is given below.

Procedure

1. Generate zero air and deliver it to the analyzer. Record zero air results and all following test points for each analyte (NO,NO₂,NO_x) on the calibration sheet.
2. Generate an NO tests gas concentration at >20% above the NO₂ Level-4 precision target concentrations range and introduce it to the analyzer. Note results for all analytes. Follow this by the generation an NO₂ test gas concentration at the Level-4 precision target concentration using gas phase titration. Note results for all analytes.
3. Repeat Step 2 for the Level-1, Level-2 and Level-3 test gas concentration ranges as describe in Table 1 above.
4. Send a final zero air to the analyzer and record the results. Calculate a least-squares linear regression between the known NO concentrations (including the zero point) as the ordinate and the zero corrected analyzer responses as the abscissa. Perform the same regression for the NO₂ and NO_x analytes. Record slope, intercept, and correlation coefficient on the calibration sheet. Also calculate, using this response curve, a %REFS for a calibrated analyzer response given a known introduced concentration of exactly 90% of the full measurement range of the analyzer.
5. The criteria for a successful calibration is where all non-zero test points after the calibration adjustment show a <+/-2% full scale error from the final best fit regression calibration line. The precision level should be as close to 0% error as possible. If the post-calibration assessment begins to show a failure at any point, and repeating previous analyzer adjustments do not solve the problem, then maintenance is probably needed for the analyzer.

Equation 18. Relative Error at Full Scale

$$\frac{[(90\% \text{ full scale} * m) + i] - 90\% \text{ full scale}}{90\% \text{ full scale}} * 100 = \%REFS$$

where:

m = slope of response curve.

i = intercept of response curve.

90% full scale = 900 ppb (calibration full scale 0-1000 ppb)

= 450 ppb (calibration full scale 0-500 ppb)

%REFS = Relative Error at Full Scale

6. Reattach the station calibrator's supply line back to its solenoid valve on the span panel.
7. Do another zero, span and precision routine like the one done before the calibration (Section 7.3.2). Record results on the calibration sheet and on the calibration sticker. These are the z/s/p values at time of calibration.
8. Calculate % of NO_x result that is due to NO₂ residual concentration in the NO station span bottle. This value is the relative concentration of NO₂ to NO in the bottle.

$$\frac{(NO_x - NO)}{NO_x} \times 100\% = \%NO_2$$

where:

NO_x = NO_x result during final span.

NO = NO result during final span.

%NO₂ = % residual NO₂ compared to NO concentration in station span bottle.

If the %NO₂ is >= 2%, the station span bottle will need to be changed out and the relevant personnel contacted.

9. Record analyzer parameters, especially the new analyzer calibration settings (slope, offset), from the front panel display on the calibration sticker and sheet.
10. Enable the NO/NO₂/NO_x channels. Record the MST time the instrument was brought back on line on the calibration sheet and on the station NO₂ log. Put the calibration sticker on a surface near the analyzer so that it is easily read.
11. Enter the calibration results in a "message to central". On the data logger message window to Central type and send:

700 read, NO sp=xxx, pr=xxx

(these are the Stat calibrator's readings when doing an NO span and precision)

200 read, NO sp=xxx, NOx sp=xxx, NO pr=xxx, NOx pr=xxx

(these are the analyzer's NO and NO_x readings during untitrated span and precision)

200 read Titr, NO2 sp=xxx, NOx sp=xxx, NO2 pr=xxx, NOx pr=xxx

(these are the analyzer's NO₂ and NO_x readings during titrated span and precision)

%NO₂ (percentage of NO₂ residual compared to NO concentration in station span bottle)

Plus type the calibration specialist's initials and any comments that are felt relevant such as non-routine actions or maintenance done.

This is a message through the data logger to the GMM unit worker responsible for tracking calibrations in the ZSPTracking database. This message is permanently stored in the AirVision system and information from this message is manually inputted into the ZSPTracking database.

In the event of a failed precalibration audit or assessment, a separate message is sent to Central in the form of

NO_x CAL FAILED AUDIT,

(in all CAPS) followed by a general description in regular text and the calibrator's initials. This is to highlight important cal/audit information for the purposes of data validation.

12. Record analyzer parameters and calibration and maintenance actions on the station NO₂ log.

9 NOY CALIBRATION PROCEDURE

9.1 Calibration Train Setup

1. Connect the clean air supply directly to the zero air input of the calibrator (Figure 1).
2. Before the NO cal gas cylinder is connected to the calibrator, its line and regulator must be purged at least three times. This is done in order to remove all ambient air from the regulator. (Ambient air in the regulator can dilute the NO and bias the calibration results and introduce ambient contaminants that interact with the NO.) The following describes the line and regulator purging action:
 - a. Open the regulator and cylinder valves. The closed quick connect will keep the cal gas from escaping
 - b. Close the cylinder valve.
 - c. Push the end of the quick connect nozzle against a clean, flat surface to partially release the pressure within the regulator and line. Carefully watch the two regulator gauges and do not let either of them fall to zero. A positive pressure compared to ambient must be kept so that room air will not surge back into the line and regulator. To stop the release of cal gas, pull the quick connect nozzle away from the flat surface.
 - d. Repeat Steps a through c two times.
 - e. Open the cylinder valve to recharge the regulator and line to full pressure as indicated by the two regulator gauges.
3. After purging, connect the NO cal gas regulator line directly to the cal gas input of the dilution calibrator. Adjust delivery pressure between 20 to 30 psi.
4. Connect a Teflon line to the exit port of the transfer standard calibrator. The length of this line should be of sufficient length to reach from the transfer standard (TS) calibrator to the back of the station (Stat) calibrator or the station analyzer. This is the transfer standard calibrator supply line (supply line). Leave this other end of this line unconnected end for now.
5. The introduction of test gas to the analyzer can be performed in one of two ways depending upon how the station calibrator is configured for the nightly performance tests. The transfer standard calibrator should be configured similarly to the station calibrator if possible. If the station calibrator is configured to introduce test gas through the probe (TTP) then the transfer standard calibrator should be configured likewise. The same is true if the station calibrator is configured to the back of the analyzer (BOA). In most situations the

site calibration line can be removed directly from the back of the station calibrator and connected to the transfer standard calibrator output line with a Teflon union. If the a solenoid manifold is used external to the station calibrator to direct test gas TTP to individual analyzers, then it is acceptable to connect the transfer standard output line to the station TTP calibration line on the output side of the solenoid. Simply disconnect the TTP calibration line from the output side of the solenoid and connect it to the transfer standard output with a Teflon union. This method eliminates the need to activate the solenoid for the entire length of the calibration.

9.2 Pre-calibration Zero, Span, and Precision Routine

This routine is done before there is adjustment to the analyzer to help correlate the preceding automatic zeros and spans (z/s) and precisions (p) with the pre-calibration audit responses. It is also done at the end of the calibration procedure to generate new official z/s/p values for the following sampling period until the next calibration. In practice these routines are started just before and after any calibration / audit to allow time to set up or tear down the calibration equipment while they run their course.

If the analyzer is communicating with the data logger over an analog connection, connect a digital volt meter (DVM) or digital chart recorder to the analog output of the monitor or the analog input of the data logger according to ease of accessibility. This step should not be performed if the analyzer is communicating with the data logger over a digital connection (GSI or Modbus).

1. Take the NO, NO_y-NO, and NO_y analyzer channels offline.
2. Start an automatic precision/zero routine. This is done by a command through the data logger (See data logger section in this QAPP document). Allow this routine to run fully until its automatic ending. During the run make sure that all readings from the front panels of the Stat calibrator and NO_y analyzer match the numbers seen in the data logger. Record the final reported numbers on the calibration (cal) sheet. A precision is done before a span because the NO_y analyzer is more sensitive to conditioning effects at this level, and the purpose of the pre-cal precision is to emulate the midnight precisions as closely as possible. Note that there will be two parts to the precision proper, a NO/NO_y component without titration to assess those two channels, and then a titration of the NO gas to NO₂. The span will also have these two components.
3. Start an automatic span/zero routine as done with step two with the precision. If a second auto zero is not needed, the automatic span/zero routine can be aborted through the data logger after the span phase is finished; but if done so, the last five minute readings of the Stat calibrator and analyzer during span must be manually averaged as no report will be provided by the data logger.
4. Zero-correct the data logger precision span test level (t) results.

Equation 19. Zero Corrected Test

$$t - \text{zero value} = \text{zero corrected test level (zct)}$$

5. Calculate the percentage relative error (%RE) of the two zct's and record on the calibration sheet.

Equation 20. Percent Relative Error

$$\frac{zct - \text{Actual Concentration}^*}{\text{Actual Concentration}^*} * 100\% = \%RE$$

*Actual Concentration is the concentration of the test gas as reported by the station calibrator through the data logger.

The pre-calibration span and precision plus station zero can also be run manually through the data logger, but the calibration specialist must be careful to emulate automatic phase times so that conditioning effect differences between previous midnight auto spans and precisions and this pre-calibration span and precision can be minimized. For some diagnostic purposes a manual running of the precision and span is sometimes more useful and practical than using the automatic routines. The manually triggering of relays through the data logger is non-routine and the procedure to perform this task is not included in this SOP. Contact the Data Manager to attain information on how to perform this task.

9.3 Pre-Calibration Audit, Calibration Adjustment and Post-Calibration Assessment

9.3.1 Pre-Calibration Audit Procedure

Introduction

From the transfer standard calibrator set up introduce zero and precision levels (including a separate titrated NO₂ precision level) test gas to the analyzer. Calculate %RE for the zero corrected precision level results. If this exceeds +/- 10 %RE, follow with a full five point (intervening with five titrated NO₂ levels) plus zero calibration assessment audit (the same as a post-calibration assessment in method below) before any adjustment is made to the analyzer. This assessment audit is the same as described below in section 8.3.3.3 Post-Calibration Assessment. This is to characterize the out-of-spec condition fully, and the information will be used during data validation.

If the analyzer fails the five point assessment audit then repairs and calibration of the instrument are done as soon as possible after the audit. If the repairs required are beyond the resources of the calibration specialist then the monitoring technician for that station is notified immediately. Proceed to the calibration adjustment procedure in Section 8.3.3.2 if the pre-calibration audit results less than +/- 10 %RE. Failed pre-calibration assessment audits require an electronic message in the data logger that will to be use for data validation purposes. The procedure for performing the pre-calibration audit is given below.

Procedure

1. If a TAPI 700x transfer standard (TS) calibrator with certified MFCs is used then simply request the desired NO/NO₂ concentration or zero point needed. Refer to the calibrator's operating manual on how to generate manual concentrations (ref 6).
2. Let the zero dilution airflow in the calibrator stabilize. This should usually take less than five minutes.
3. The station calibrator tests the analyzer through the sample probe with the station supply line. Detach the station calibrator's supply line after the last station calibrator external solenoid valve and attach the transfer standard calibrator's supply line directly to the station supply line end with a union.
4. Send zero air through the probe to the analyzer from the transfer standard calibrator. Be sure that excess supply flow at the probe is 20 to 50% greater than analyzer flow (compare total flow readings on the analyzer and transfer standard calibrator).
5. Allow at least five minutes after the analyzer has stabilized. Record the NO, NO_y-NO, and NO_y results on the calibration sheet. This is the pre-calibration zero air concentration reading.
6. Generate a test precision concentration of NO that is approximately 20-85 % higher than the desired NO₂ concentration. Precision levels are typically between 10 and 20% of the calibration range of the analyzer. The MFCs in the transfer standard calibrator should not be used below 10% or above 90% of their full scale for older TAPI 700xs. Some of the newer MFCs in newer TAPI 700xs are capable of using an upper range of 99% of their full scale, but if in doubt use the more constricted range when generating a concentration while keeping in mind that an excess of gas must be provided to the probe. Record the NO, NO_y-NO, and NO_y results on the calibration sheet.

7. Titrate off of this NO precision the NO₂ precision level immediately afterwards. NOTE: When titrating from a given NO level, do not leave less than 20% or more than 80% of the original NO concentration. This will minimize back reactions between NO and NO₂. Allow at least five minutes after a stable response from the analyzer is achieved. Record the NO, NO_y-NO, and NO_y results on the calibration sheet. Zero-correct the results.

Calculate the relative error of the analyzer’s response

Equation 21. Percent Relative Error

$$\frac{\text{Analyzer Reading} / (\text{DAS}) - \text{true}[\text{NO}, \text{NO}_y]}{\text{true}[\text{NO}, \text{NO}_y]} * 100\% = \%RE$$

8. Percent relative error is determined for each channel on the analyzer (NO, NO_y-NO, and NO_y). If the precision level error for each channel is < +/- 10% RE a full assessment audit is not required, proceed to 8.3.3.2. If it equals or exceeds +/-10%RE, follow with a full four point plus zero calibration assessment audit (the same as a post-calibration assessment in section 8.3.3.3 below) before any adjustment or repairs are made to the analyzer. This is to characterize the out-of-spec condition fully, and the information will be used during data validation. Additionally, if the assessment fails, documentation of this failure in a Message to Central is required as described in Section 8.3.3.3 Step 10.

9.3.2 Calibration Adjustment

Introduction

After the pre-calibration audit, the analyzer is adjusted (calibrated) at the zero and precision level so that the analyzer most closely matches the known concentrations produced by the calibration system. After this is done, a five level plus zero multipoint calibration assessment (8.3.3.3) is reintroduced to characterize the analyzer response over the entire measurement range. The calibration points are generated by diluting a higher concentration of NO from a NIST-traceable calibration gas to a target concentration. The recommended ranges for the multi-point calibration points are detailed in Table 6. As each calibration point is generated, the responses shown by the data logger should be compared to the calibrator value.

Table 6. Calibration Ranges for Oxides of Nitrogen Analyzers

Units	Parts per billion (ppb)
Calibration Scale	0 to 1000 ppb
Compressed gas cylinder	15-25 ppm*
* Based on calibrator mfc ranges: gas1 = 50mL/min, gas2 = 100 mL/min, dil = 10 or 20 L/min	
<u>Calibration points</u>	
Level 1	750-1000 ppb
Level 2	500–750 ppb
Level 3	250–500 ppb
Level 4	50–250 ppb
Level 5 - zero	0 ppb

Level 4 is the accepted precision level that is used to adjust the calibration of the analyzer with as little error as possible (along with Level 5, or the zero level).

Procedure

1. To start the analyzer calibration adjustment, introduce zero air again to the analyzer and let the chart trace stabilize.

If any of the three channels do not display zero for the concentration reading, on the analyzer's front panel press CAL. ZERO will appear. Press this. Display concentration will go to 0.000. This is the calibration adjustment of the zero level.

2. Generate another precision level and introduce to the analyzer again. Let the chart trace stabilize.
3. Press Cal. CONC will appear. Press this. NO SPAN CONC: XXX.X CONC will appear. Using buttons, input NO and NO_y precision concentration as displayed by the transfer standard calibrator. Press ENTER. This is the calibration adjustment of the precision level.
4. Steps 1 thru 3 can be repeated if the calibration settings from the initial calibration or subsequent calibrations are not sufficiently accurate. This is accomplished by independently sending zero air and known test gas concentrations (10 to 20% of calibration full scale) to the analyzer to assess the accuracy of the calibration. If the results are not optimal, repeat steps 1 thru 3. Several jumps between the zero air and the test gas, along with calibration adjustments, may be required. Record the calibration results on the calibration sheet.
5. If the NO_y channel changes from its untitrated concentration during an NO₂ input during titration, then the analyzer's electronic Converter Efficiency (a correction constant in memory) will need to be adjusted. Send about a 60% full scale NO into the analyzer and note the NO_y reading. Off of this same high level NO concentration, titrate a high level NO₂ (keeping in mind the 15 and 85% titration constraints). Note how much the NO_y channel changes. In the analyzer's CAL menu go to the NO₂ CONC. Take the real time NO₂ reading and correct this by how much the NO_y channel changed between no-titration and titration. (e.g. if the NO_y channel went up 3ppb during titration, then correct the real time NO₂ reading by subtracting 3ppb from it) Enter this corrected NO_y-NO value in the NO₂ CONC field and press ENTER. The new Converter Efficiency will be calculated automatically and a new correction constant stored in memory. NOTE: if the new CE is less than 97.5% as read in the menu, then the calibration will need to be stopped and maintenance on the analyzer performed. The converter efficiency determined here is based upon NO₂. The routine convertor efficiency checks that are performed weekly are based upon NO₂ and iso-propylnitrate or n-propylnitrate.

9.3.3 Post-Calibration Assessment

Introduction

The post-calibration assessment challenges the analyzer with five different test gas concentrations levels plus a zero to evaluate the accuracy of the new calibration. The assessment begins with a zero point followed by points at <20% (Level 4 - precision), >80% (Level 1 - span), ~60% (Level 2), and ~40% (Level 3). Results for these tests are used to evaluate the relative error at full scale. Concentration levels are generated as described in the pre-calibration assessment (7.3.3.1). Note: Generated NO concentrations should be at least 20% greater than the desired NO_y-NO target concentrations. This is to allow for a 20% NO residual that is required during the gas phase titration phase. It is acceptable to generate and evaluate the NO/NO_y channels at concentration levels slightly higher than the desired NO_y-NO concentration levels. The procedure for performing the post-calibration assessment is given below.

1. Generate zero air and deliver it to the analyzer. Record zero air results and all following test points for each analyte (NO, NO_y-NO, and NO_y) on the calibration sheet.

2. Generate an NO tests gas concentration at >20% above the NO_y-NO Level-4 precision target concentrations range and introduce it to the analyzer. Note results for all analytes. Follow this by the generation an NO₂ test gas concentration at the NO_y-NO Level-4 precision target concentration using gas phase titration. Note results for all analytes.
3. Repeat Step 2 for the Level-1, Level-2 and Level-3 test gas concentration ranges as describe in Table 2 above.
4. Send a final zero air to the analyzer and record the results. Calculate a least-squares linear regression between the known NO concentrations (including the zero point) as the ordinate and the zero corrected analyzer responses as the abscissa. Perform the same regression for the NO_y-NO and NO_y channels. Record slope, intercept, and correlation coefficient on the calibration sheet. Also calculate, using this response curve, a %REFS for a calibrated analyzer response given a known introduced concentration of exactly 90% of the full measurement range of the analyzer.
5. The criteria for a successful calibration is where all non-zero test points after the calibration adjustment show a <+/-2% full scale error from the final best fit regression calibration line. The precision level should be as close to 0% error as possible. If the post-calibration assessment begins to show a failure at any point, and repeating previous analyzer adjustments do not solve the problem, then maintenance is probably needed for the analyzer.

Equation 22. Relative Error at Full Scale

$$\frac{[(90\% \text{ full scale} * m) + i] - 90\% \text{ full scale}}{90\% \text{ full scale}} * 100 = \%REFS$$

where:

m = slope of response curve.

i = intercept of response curve.

90% full scale = 900 ppb (calibration full scale 0-1000 ppb)

%REFS = Relative Error at Full Scale

6. Reattach the station calibrator supply line back on the Cal In port on the 501Y.
7. Do another zero, span and precision routine like the one done before the calibration (Section 8.3.2). Record results on the calibration sheet and on the calibration sticker. These are the z/s/p values at time of calibration.
8. Calculate % of NO_x result that is due to NO₂ residual concentration in the NO station span bottle. This value is the relative concentration of NO₂ to NO in the bottle.

$$\frac{(NO_x - NO)}{NO_x} * 100\% = \%NO_2$$

where:

NO_x = NO_x result during final span.

NO = NO result during final span.

%NO₂ = % residual NO₂ compared to NO concentration in station span bottle.

If the %NO₂ is \geq 2%, the station span bottle will need to be changed out and the relevant personnel contacted.

9. Record analyzer parameters, especially the new analyzer calibration settings, from the front panel display on the calibration sticker and sheet.
10. Enable the NO, NO₂, and NO_y channels. Record the MST time the instrument was brought back on line on the calibration sheet and on the station NO₂ log. Put the calibration sticker on a surface near the analyzer so that it is easily read.
11. On the data logger message window to Central type and send:

700 read, NO sp=xxx, pr=xxx

(These are the Station calibrator's readings when doing an NO span and precision)

200 read, NO sp=xxx, NO_y sp=xxx, NO pr=xxx, NO_y pr=xxx

(these are the analyzer's NO and NO_y readings during untitrated span and precision)

200 read Titr, NO₂ sp=xxx, NO_y sp=xxx, NO₂ pr=xxx, NO_y pr=xxx

(These are the analyzer's NO₂ and NO_y readings during titrated span and precision)

%NO₂ (percentage of NO₂ residual compared to NO concentration in station span bottle)

Plus type the calibration specialist's initials and any comments that are felt relevant such as non-routine actions or maintenance done.

This is a message through the data logger to the GMM unit worker responsible for tracking calibrations in the ZSPTracking database. This message is permanently stored in the AirVision system and information from this message is manually inputted into the ZSPTracking database.

In the event of a failed precalibration audit or assessment, a separate message is sent to Central in the form of

NO_y CAL FAILED AUDIT,

(in all CAPS) followed by a general description in regular text and the calibrator's initials. This is to highlight important cal/audit information for the purposes of data validation.

12. Record analyzer parameters and calibration and maintenance actions on the station NO_y log.

10 REPORTING AND FILING OF CALIBRATION RESULTS

The results of a calibration or assessment check are recorded and reported by the calibration specialist as follows (this is a summary; some of these actions have already been mentioned):

1. Record analyzer parameters, calibration and maintenance actions, cal date, beginning/ending disabled time and calibration specialist's initials on the station logs.
2. Record the calibration and check points, linear regression results, cal date and calibration specialist's initials on the calibration report form (Figure 11) and in the Calibrations database (Figure 11), along with relevant comments. If possible and if the required computer and software are available download the data stored in the analyzer's own internal data logger.

3. Any unusual thing seen at a station, even if rectified by the calibration specialist, is reported that day to the field technician and recorded in the station logs
4. Record uncorrected data logger and chart z/s/p results, analyzer calibration settings, cal date and calibration specialist's initials on the station sticker.
5. Put the calibration sheet with all of the calibration information, beginning/ending disabled time, cal date and calibration specialist's initials into the specially designated ring binder at the home office. Each year of calibrations and assessment checks has its own binder. The most recent four to five years of calibration and assessment audit sheets are kept at the home office. Older binders are put into permanent storage.
6. Calibration records in the Calibrations database, located on local PCs, are uploaded to the J:Drive Master Calibration database monthly for centralized archiving.

11 QUALITY ASSURANCE AND QUALITY CONTROL

11.1.1 Calibrations

Calibration of an analyzer or instrument establishes the quantitative relationship between the actual value of a standard, be it a pollutant concentration, a temperature, or a mass value, and the analyzer's response (chart recorder reading, output volts, digital output, etc.). This relationship is used to convert subsequent analyzer response values to corresponding concentrations. Once an instrument's calibration relationship is established, it is checked at reasonable frequencies to verify that it remains in calibration. It is the goal of APCD to perform calibrations on all analyzers quarterly, however, circumstances may require calibrations be performed at the longer frequency of every 6-months. A 6-month calibration frequency still meets EPA recommended calibration frequency criteria.

11.1.2 Documentation

Documentation is an important component of the quality control system. Extensive certification paperwork and log sheet must be rigorously maintained for procedures, standards and analyzers. APCD takes special care to prepare and preserve backup copies of all data, especially calibration data. All data and supporting documentation should be held on-site for a minimum of three calendar years then sent for offsite archive.

12 BIBLIOGRAPHY

- Agilaire. (2009). *AirVision Version I*. Knoxville, TN: Agilaire LLC.
- Agilaire. (2013). *Agilaire Model 8872 Manual*. Knoxville, TN: Agilaire LLC.
- Environmental Systems Corporation. (2001). *ESC Model 8816 Data Logger Engineering Manual*. Knoxville, TN: Environmental Systems Corporation.
- Environmental Systems Corporation. (2006). *ESC Model 8832 Data Logger Engineering Manual*. Knoxville, TN: Environmental Systems Corporation.
- Mesa Laboratories. (MK01-26 Rev H). *Definer 220 Series User Manual*. Butler, NJ: Mesa Laboratories.
- Teledyne-API. (2009). *Operation Manual - Model 700E Dynamic Dilution Calibrator*. San Diego, CA: Teledyne-API. Retrieved from http://www.teledyne-api.com/manuals/05621B4_700E.pdf
- Teledyne-API. (2010). *Operation Manual - Model 701H High Performance Zero Air Generator*. San Diego, CA: Teledyne-API. Retrieved from http://www.teledyne-api.com/manuals/06712B_701H.pdf
- Thermo Scientific. (2007). *Instruction Manual - Model 48i Trace Level-Enhanced Gas Filter Correlation CO Analyzer*. Franklin, MA: Thermo Scientific.
- US EPA. (1979). *Technical Assistance Cocument for the Calibration of Ambient Ozone Monitors*. Research Triangle Park, NC: US EPA.
- US EPA. (1990). *Measurement Principle and Calibration Procedure for the Measurement of Carbon Monoxide in the Atmosphere (Non-Dispersive Infared Photometry), 40CFR50,AppC (1990)*. US EPA.

US EPA. (2005). *Technical Assistance Document for Precursor Gas Measurements in the NCore Multi-pollutant Monitoring Network*. Research Triangle Park, NC: US EPA.

US EPA. (2007). *Guidance for Preparing Standard Operating Procedures*. Research Triangle Park, NC: US EPA OAQPS AQAD.

US EPA. (2013). *Quality Assurance Handbook for Air Pollution Measurement Systems, Volume 2*. RTP, N: US EPA.

US EPA. (2013). *Quality Assurance Handbook for Air Pollution Measurement Systems, Volume 2*. RTP, N: US EPA.

US EPA. (2013). *Technical Assistance Document - Transfer Standards For Calibration of Air Monitoring Analyzers for Ozone*. Research Triangle Park, NC: US EPA.

CO Calibration Setup

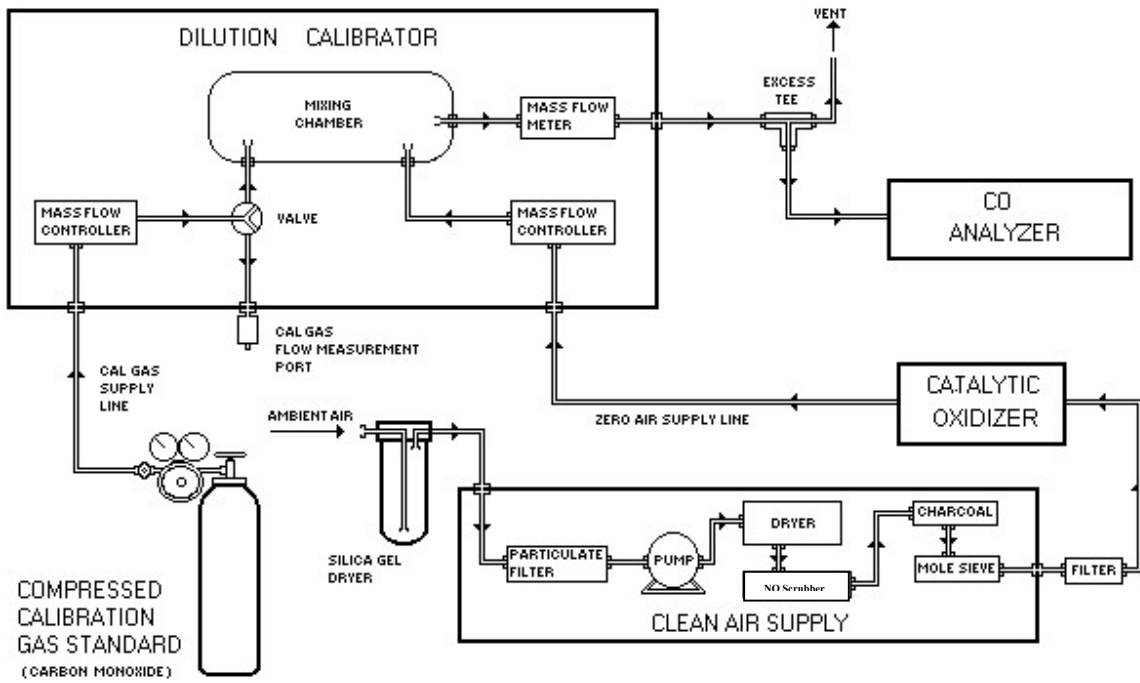

Figure 1. CO Calibration Setup

SO₂ Calibration Setup

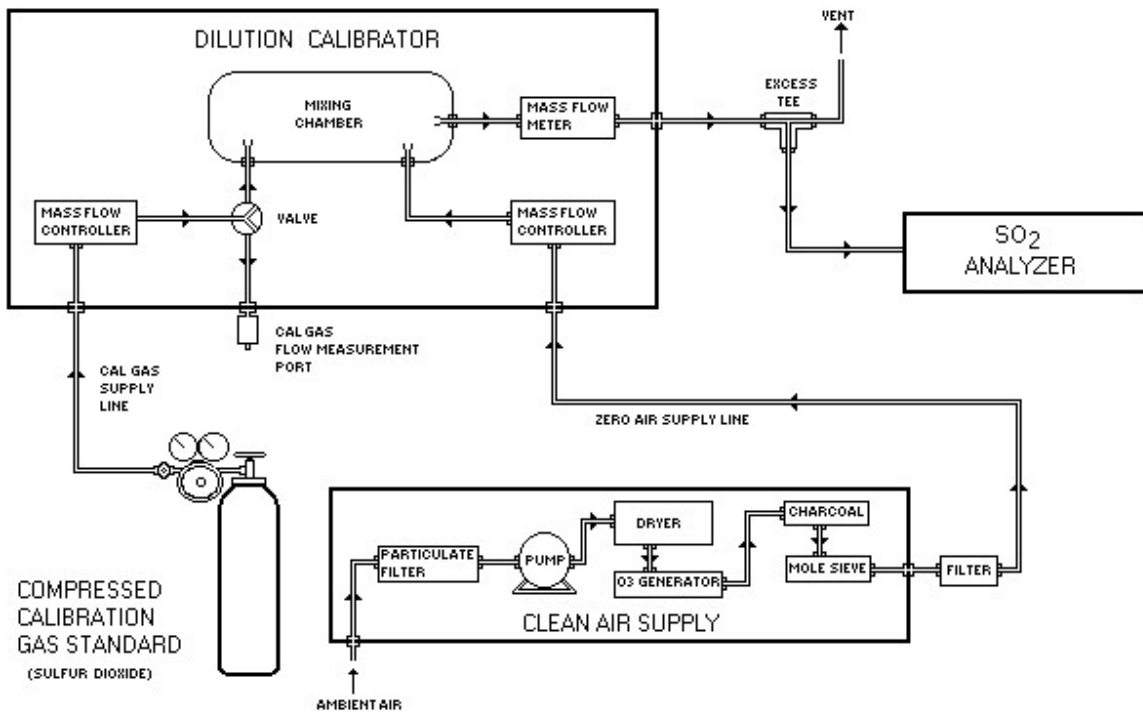

Figure 2. SO₂ Calibration Setup

Ozone Calibration Setup

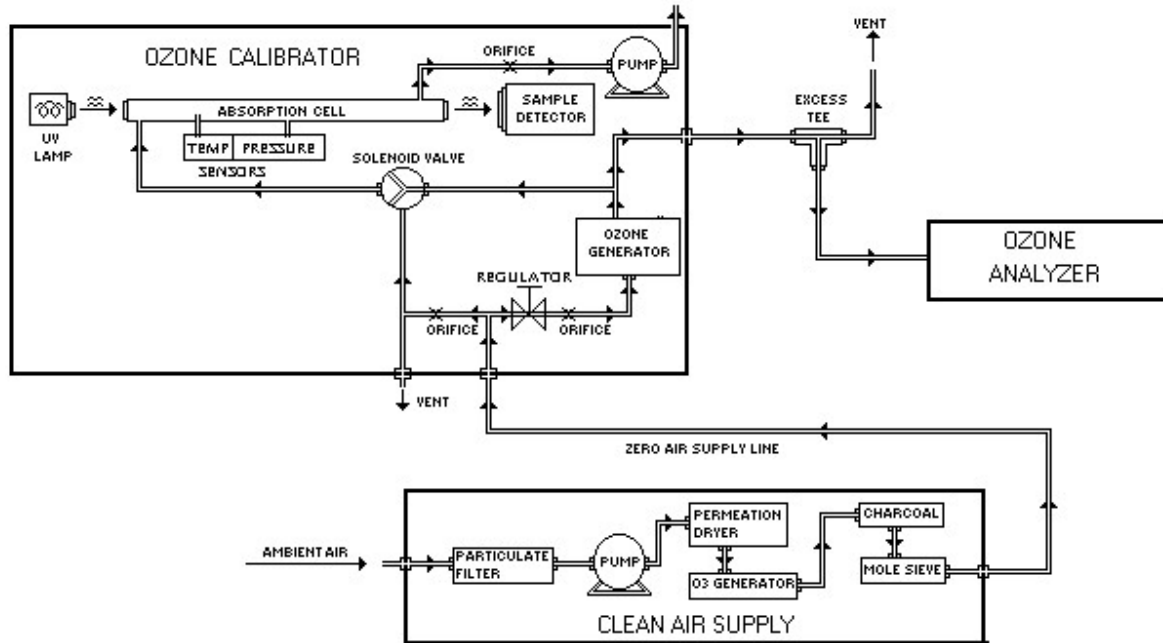

Figure 3. O₃ Calibration Setup

NO_x Calibration Setup

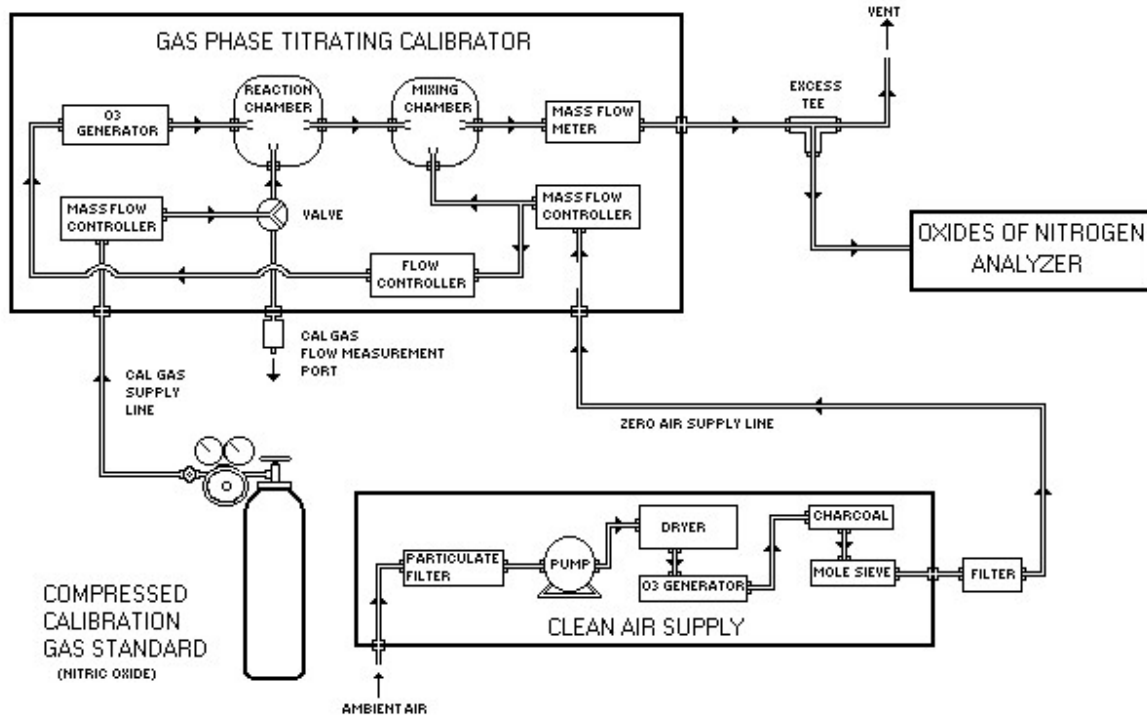

Figure 4. NO / NO₂ / NO_x Calibration Setup

NO_x Calibration Setup

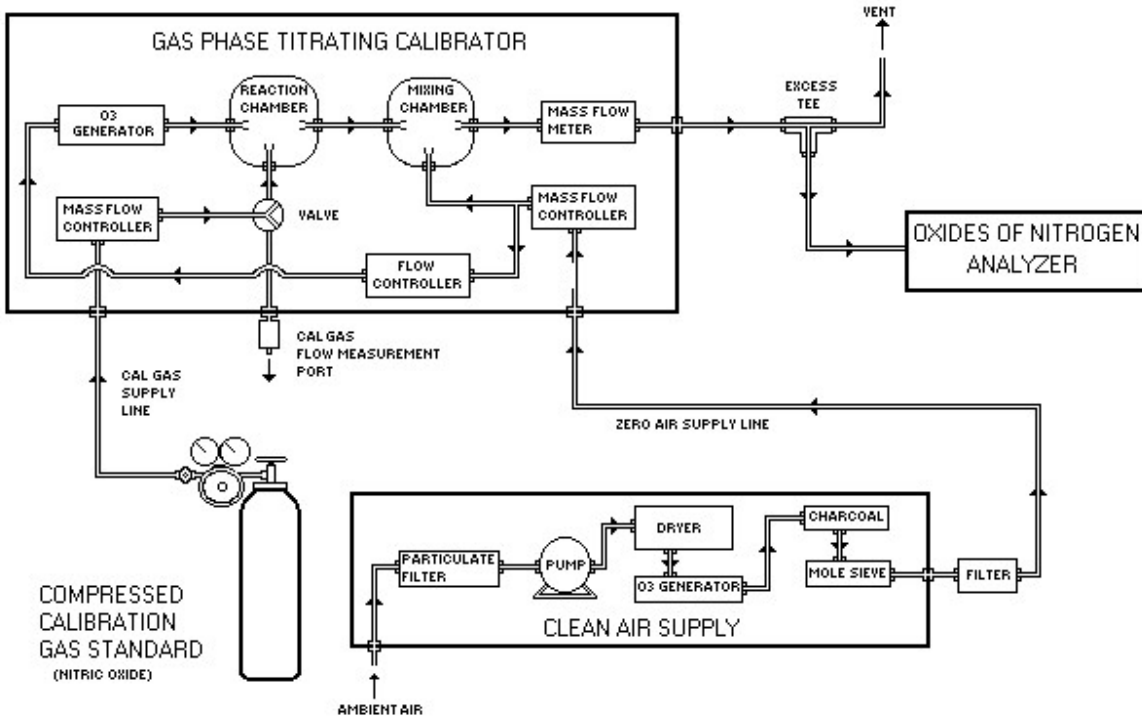

Figure 5. NO_y Calibration Setup

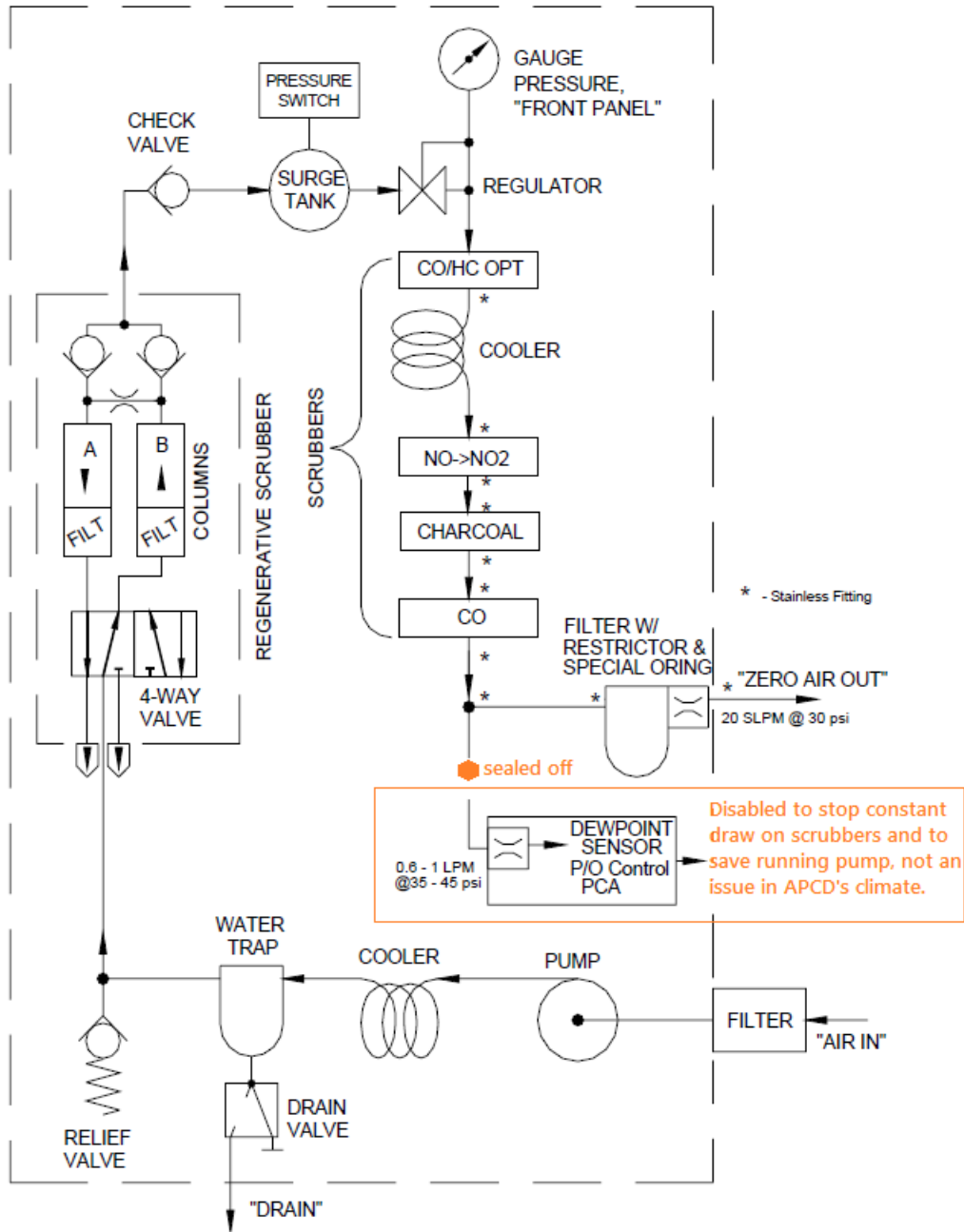

Figure 6. Typical zero-air supply system - TAP 701H

FLOW MEASUREMENT

STATION _____ DATE _____
 CALIBRATOR _____ ZERO AIR _____ VAC = _____ " PSI = _____ "
 GAS STD CYL # _____ CATALYTIC OXIDIZER at _____ mv/ _____ F/C
 REG PRESS = _____ / _____ CONC = _____

CAL SETTING	RAW FLOW MEASURED	AVG FLOW	TEMP °C	(BP-Pv) * 298.2 29.92 * (273.1 T)	FLOW CONC * PPM @STP (Fd + Fg)	Fg	OUT
		$\bar{X} =$	$\bar{X} =$	(____ - ____) * 298.2 29.92 * (273.2 +) CF =			
		$\bar{X} =$	$\bar{X} =$	(____ - ____) * 298.2 29.92 * (273.2 +) CF =			
		$\bar{X} =$	$\bar{X} =$	(____ - ____) * 298.2 29.92 * (273.2 +) CF =			
		$\bar{X} =$	$\bar{X} =$	(____ - ____) * 298.2 29.92 * (273.2 +) CF =			
		$\bar{X} =$	$\bar{X} =$	(____ - ____) * 298.2 29.92 * (273.2 +) CF =			
		$\bar{X} =$	$\bar{X} =$	(____ - ____) * 298.2 29.92 * (273.2 +) CF =			
		$\bar{X} =$	$\bar{X} =$	(____ - ____) * 298.2 29.92 * (273.2 +) CF =			

CALIBRATOR FLOW Rotometer _____ Total _____ Excess _____ FLOW STANDARD = Make and SN # _____ or HBM - 1 # _____ mb

- BP = Barometric Pressure "Hg
- STP = 25° C & 29.92 "Hg
- Fd = Flow rate of dilution air
- Fg = Flow rate of gas standard
- Pv = Vapor
- T = Temperature
- CF = Correction Factor (dimensionless) to compensate flow for temp/barometric pressure

Figure 9. Flow Measurement



COLORADO DEPARTMENT OF PUBLIC HEALTH AND ENVIRONMENT

Air Pollution Control Division - Technical Services Program
 Ozone, Carbon Monoxide, Sulfur Dioxide Calibration Form



Site Name: _____						
Site Info.		Date Time			Calibration Equipment Info	
AQS ID: _____		Date (mm/dd/yy) _____			Calibrator Type: _____	
Parameter: _____		Time (hh:mm) _____			Calibrator SN: _____	
Analyzer Type: _____		Prev. Cal. Date (mm/dd/yy) _____			Calibrator Cert Date: _____	
Analyzer SN: _____		Calibrator's Initials: _____			Cert. Slope (m): 1.00000	
Site Precision Source Info.					Cert. Intercept (b): 0.00000	
Source Type: _____					Calibration Gas Info.	
Source SN: _____					Bottle SN: _____	
Conc.: _____					Conc.: _____	
Exp. Date: _____					Exp. Date: _____	
Pre-Calibration System ZSP Evaluation				Post-Calibration System ZSP Evaluation		
Pre-Calibration Analyzer Slope: _____				Post-Calibration Analyzer Slope: _____		
Pre-Calibration Analyzer Intercept: _____				Post-Calibration Analyzer Intercept: _____		
Set Point	Source Conc.	Display Conc.	DAS Conc.	Display % Diff	DAS % Diff	
Zero						
Span						
Precision						
Pre-Calibration Points				Post-Calibration Points		
Set Point	Conc. Out Conc.	DAS Conc.	Conc. Adj Conc.	DAS % Diff	Best Fit DAS Conc.	Best Fit (% RE)
Zero						
Level 1						
Level 2						
Level 3						
Level 4						
Level 5						
Level 6						
Level 7						
Pre - Regression Results				Post - Regression Results		
Slope: _____				Slope: _____		
Intercept: _____				Intercept: _____		
R2: _____				R2: _____		
Comments:						

Figure 10. Calibration Report



**Oxides of Nitrogen (NO, NO₂, NO_x, NO_y)
 Calibration Form**

Site Name: <input style="width:90%;" type="text"/>											
Site Info.				Date Time				Calibration Equipment Info			
AQS ID: <input type="text"/>				Date (mm/ dd/ yy) <input type="text"/>				Calibrator Type: <input type="text"/>			
Parameter: <input type="text"/>				Prev Cal. Date (mm/ dd/ yy) <input type="text"/>				Calibrator SN: <input type="text"/>			
Analyzer Type: <input type="text"/>				Calibrator's Initials: <input type="text"/>				Calibrator Cert Date: <input type="text"/>			
Analyzer SN: <input type="text"/>								Bottle SN: <input type="text"/>			
Cal Full Scale: <input type="text"/>								Cal Bottle NO Conc: <input type="text"/>			
								Cal Bottle NO _x Conc: <input type="text"/>			
								Exp. Date: <input type="text"/>			

Pre-Cal System QC NO				Pre-Cal System QC NO ₂ (NO _y -NO)				Pre-Cal System QC NO _x or NO _y		
Pre-Cal Analyzer Slope: <input type="text"/>				Pre-Calibration CE Set : <input type="text"/>				Pre-Cal Analyzer Slope: <input type="text"/>		
Pre-Cal Intercept: <input type="text"/>								Pre-Cal Intercept: <input type="text"/>		
Set Point	Source	NO only	DAS	Source	NO GPT	NO ₂ GPT	DAS	Source	NO _x GPT	DAS
	NO Conc	DAS Conc.	%Diff	NO ₂ Conc	DAS Conc	DAS Conc	%Diff	NO _x Conc	DAS Conc	%Diff
Zero	<input type="text"/>	<input type="text"/>	<input type="text"/>	<input type="text"/>	<input type="text"/>	<input type="text"/>	<input type="text"/>	<input type="text"/>	<input type="text"/>	<input type="text"/>
Span	<input type="text"/>	<input type="text"/>	<input type="text"/>	<input type="text"/>	<input type="text"/>	<input type="text"/>	<input type="text"/>	<input type="text"/>	<input type="text"/>	<input type="text"/>
Precision	<input type="text"/>	<input type="text"/>	<input type="text"/>	<input type="text"/>	<input type="text"/>	<input type="text"/>	<input type="text"/>	<input type="text"/>	<input type="text"/>	<input type="text"/>

Pre-Calibration Assessment													
NO				Linearity	NO ₂ /NO _y -NO				Linearity	NO _x /NO _y			Linearity
Set Point	Source	DAS	Diff/ %	%at Point	Source Corr	DAS	Diff/ %	%at Point	Source	DAS	Diff/ %	%at Point	
Zero	<input type="text"/>	<input type="text"/>	<input type="text"/>	<input type="text"/>	<input type="text"/>	<input type="text"/>	<input type="text"/>	<input type="text"/>	<input type="text"/>	<input type="text"/>	<input type="text"/>	<input type="text"/>	
Level 1	Titration Level 1				Titration Level 1				Titration Level 1				
Titration Level 1	<input type="text"/>	<input type="text"/>	<input type="text"/>	<input type="text"/>	<input type="text"/>	<input type="text"/>	<input type="text"/>	<input type="text"/>	<input type="text"/>	<input type="text"/>	<input type="text"/>	<input type="text"/>	
Titration Level 1	<input type="text"/>	<input type="text"/>	<input type="text"/>	<input type="text"/>	<input type="text"/>	<input type="text"/>	<input type="text"/>	<input type="text"/>	<input type="text"/>	<input type="text"/>	<input type="text"/>	<input type="text"/>	
Titration Level 1	<input type="text"/>	<input type="text"/>	<input type="text"/>	<input type="text"/>	<input type="text"/>	<input type="text"/>	<input type="text"/>	<input type="text"/>	<input type="text"/>	<input type="text"/>	<input type="text"/>	<input type="text"/>	
Level 2	Titration Level 2				Titration Level 2				Titration Level 2				
Titration Level 2	<input type="text"/>	<input type="text"/>	<input type="text"/>	<input type="text"/>	<input type="text"/>	<input type="text"/>	<input type="text"/>	<input type="text"/>	<input type="text"/>	<input type="text"/>	<input type="text"/>	<input type="text"/>	
Titration Level 2	<input type="text"/>	<input type="text"/>	<input type="text"/>	<input type="text"/>	<input type="text"/>	<input type="text"/>	<input type="text"/>	<input type="text"/>	<input type="text"/>	<input type="text"/>	<input type="text"/>	<input type="text"/>	
Titration Level 2	<input type="text"/>	<input type="text"/>	<input type="text"/>	<input type="text"/>	<input type="text"/>	<input type="text"/>	<input type="text"/>	<input type="text"/>	<input type="text"/>	<input type="text"/>	<input type="text"/>	<input type="text"/>	
Level 3	Titration Level 3				Titration Level 3				Titration Level 3				
Titration Level3	<input type="text"/>	<input type="text"/>	<input type="text"/>	<input type="text"/>	<input type="text"/>	<input type="text"/>	<input type="text"/>	<input type="text"/>	<input type="text"/>	<input type="text"/>	<input type="text"/>	<input type="text"/>	
Titration Level 3	<input type="text"/>	<input type="text"/>	<input type="text"/>	<input type="text"/>	<input type="text"/>	<input type="text"/>	<input type="text"/>	<input type="text"/>	<input type="text"/>	<input type="text"/>	<input type="text"/>	<input type="text"/>	
Titration Level 3	<input type="text"/>	<input type="text"/>	<input type="text"/>	<input type="text"/>	<input type="text"/>	<input type="text"/>	<input type="text"/>	<input type="text"/>	<input type="text"/>	<input type="text"/>	<input type="text"/>	<input type="text"/>	
Level 4	Titration Level 4				Titration Level 4				Titration Level 4				
Titration Level 4	<input type="text"/>	<input type="text"/>	<input type="text"/>	<input type="text"/>	<input type="text"/>	<input type="text"/>	<input type="text"/>	<input type="text"/>	<input type="text"/>	<input type="text"/>	<input type="text"/>	<input type="text"/>	
Titration Level 4	<input type="text"/>	<input type="text"/>	<input type="text"/>	<input type="text"/>	<input type="text"/>	<input type="text"/>	<input type="text"/>	<input type="text"/>	<input type="text"/>	<input type="text"/>	<input type="text"/>	<input type="text"/>	
Titration Level 4	<input type="text"/>	<input type="text"/>	<input type="text"/>	<input type="text"/>	<input type="text"/>	<input type="text"/>	<input type="text"/>	<input type="text"/>	<input type="text"/>	<input type="text"/>	<input type="text"/>	<input type="text"/>	
Level 5	Titration Level 5				Titration Level 5				Titration Level 5				
Titration Level 5	<input type="text"/>	<input type="text"/>	<input type="text"/>	<input type="text"/>	<input type="text"/>	<input type="text"/>	<input type="text"/>	<input type="text"/>	<input type="text"/>	<input type="text"/>	<input type="text"/>	<input type="text"/>	
Titration Level 5	<input type="text"/>	<input type="text"/>	<input type="text"/>	<input type="text"/>	<input type="text"/>	<input type="text"/>	<input type="text"/>	<input type="text"/>	<input type="text"/>	<input type="text"/>	<input type="text"/>	<input type="text"/>	
Level 6	<input type="text"/>	<input type="text"/>	<input type="text"/>	<input type="text"/>	<input type="text"/>	<input type="text"/>	<input type="text"/>	<input type="text"/>	<input type="text"/>	<input type="text"/>	<input type="text"/>	<input type="text"/>	
Level 7	<input type="text"/>	<input type="text"/>	<input type="text"/>	<input type="text"/>	<input type="text"/>	<input type="text"/>	<input type="text"/>	<input type="text"/>	<input type="text"/>	<input type="text"/>	<input type="text"/>	<input type="text"/>	

NO Pre - Regression Results				NO ₂ Post - Regression Results				NO _x / NO _y Pre - Regression Results			
Slope: <input type="text"/>				Slope: <input type="text"/>				Slope: <input type="text"/>			
Intercept: <input type="text"/>				Intercept: <input type="text"/>				Intercept: <input type="text"/>			
R2: <input type="text"/>				R2: <input type="text"/>				R2: <input type="text"/>			

Figure 11. NO_x Specific Calibration Report

Post-Calibration Assessment														
NO				Linearity	NO2/NOy-NO				Linearity	NOx/NOy				Linearity
Set Point	Source	DAS	Diff/ %	%at Point	Source Corr	DAS	Diff/ %	%at Point	Source	DAS	Diff/ %	%at Point		
Zero														
Level 1					Titration Level 1									
Titration Level 1														
Titration Level 1														
Titration Level 1														
Level 2					Titration Level 2									
Titration Level 2														
Titration Level 2														
Titration Level 2														
Level 3					Titration Level 3									
Titration Level 3														
Titration Level 3														
Level 4					Titration Level 4									
Titration Level 4														
Level 5					Titration Level 5									
Titration Level 5														
Level 6														
Level 7														
NO Pre - Regression Results					NO2 Post - Regression Results					NOx / NOy Pre - Regression Results				
Slope:					Slope:					Slope:				
Intercept:					Intercept:					Intercept:				
R2:					R2:					R2:				
Post-Cal System QC NO				Post-Cal System QC NO2 (NOy-NO)				Post-Cal System QC NOx or NOy						
Post-Cal Analyzer Slope:				Post-Calibration CE Set :				Post-Cal Analyzer Slope:						
Post-Cal Intercept:				Post-Cal Intercept:				Post-Cal Intercept:						
Set Point	Source	NO only	DAS	Source	NO GPT	NO2 GPT	DAS	Source	NOx GPT	DAS				
	NO Conc	DAS Conc.	%Diff	NO2 Conc	DAS Conc	DAS Conc	%Diff	NOx Conc	DAS Conc	%Diff				
Zero														
Span														
Precision														
Comments:								Calibration Acceptance Criteria (<=)						
								Maximum Slope Deviation (+/-%) :				5%		
								%Diff from Best Fit Line (+/-%) :				3%		
								Zero Criteria (ppb) < :				3		

Figure 11. Calibration Report (Continued)