

**NOTES**

1. ALTERNATE 1 (PAVED SURFACE) IS REQUIRED FOR PRIVATE STREETS/ROADS SUBJECT TO THE LAND DEVELOPMENT REGULATIONS.
2. ALTERNATE 2 (ALL WEATHER SURFACE) IS PERMITTED FOR DRIVEWAYS AND FOR PRIVATE STREETS/ROADS SUBJECT TO THE LAND DEVELOPMENT REGULATIONS.
3. ADDITIONAL EASEMENTS MAY BE REQUIRED FOR CUT AND FILL SLOPES, DRAINAGE STRUCTURES AND MAINTENANCE.
4. CURB AND GUTTER AND/OR DITCHES ARE REQUIRED FOR PRIVATE STREETS SUBJECT TO THE LAND DEVELOPMENT REGULATION.
5. SEE SECTION 3.7.8 FOR ADDITIONAL DESIGN CRITERIA.

FILE: TEMP-17

**DRIVEWAY/PRIVATE STREET/ROAD & NON-MAINTAINED STREET/ROAD in COUNTY ROW**

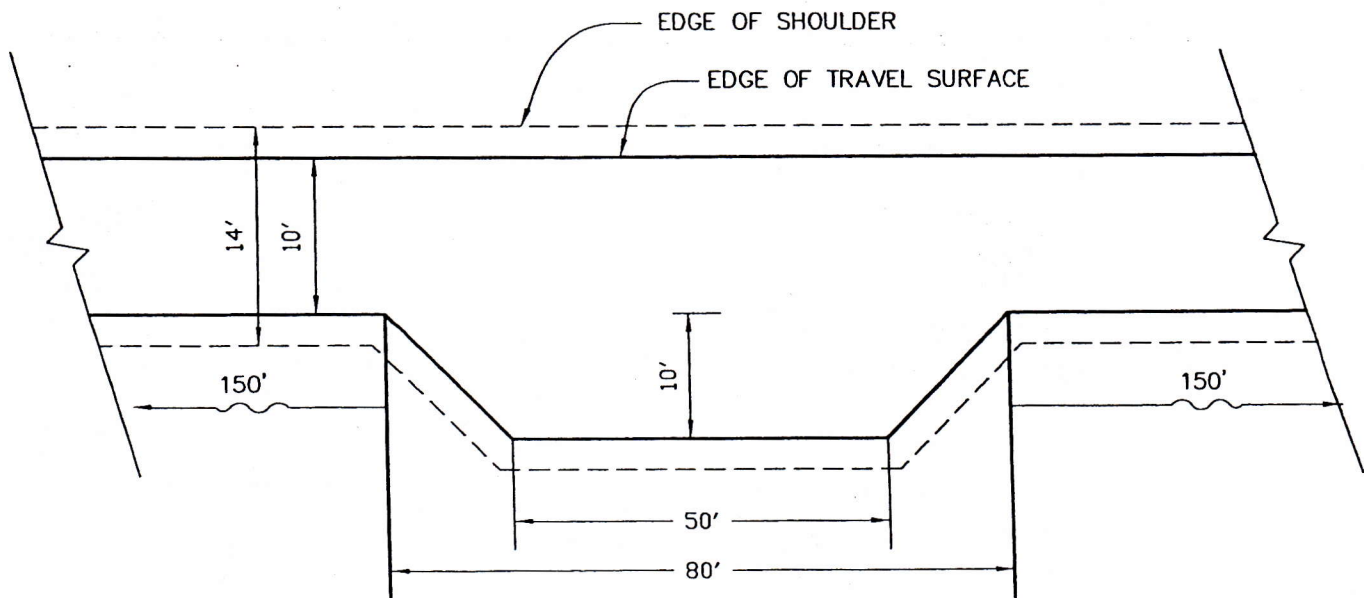

FILE: TEMP-19

**PULL OUT FOR PRIVATE STREET/ROAD**